

6

5

4

3

2

1

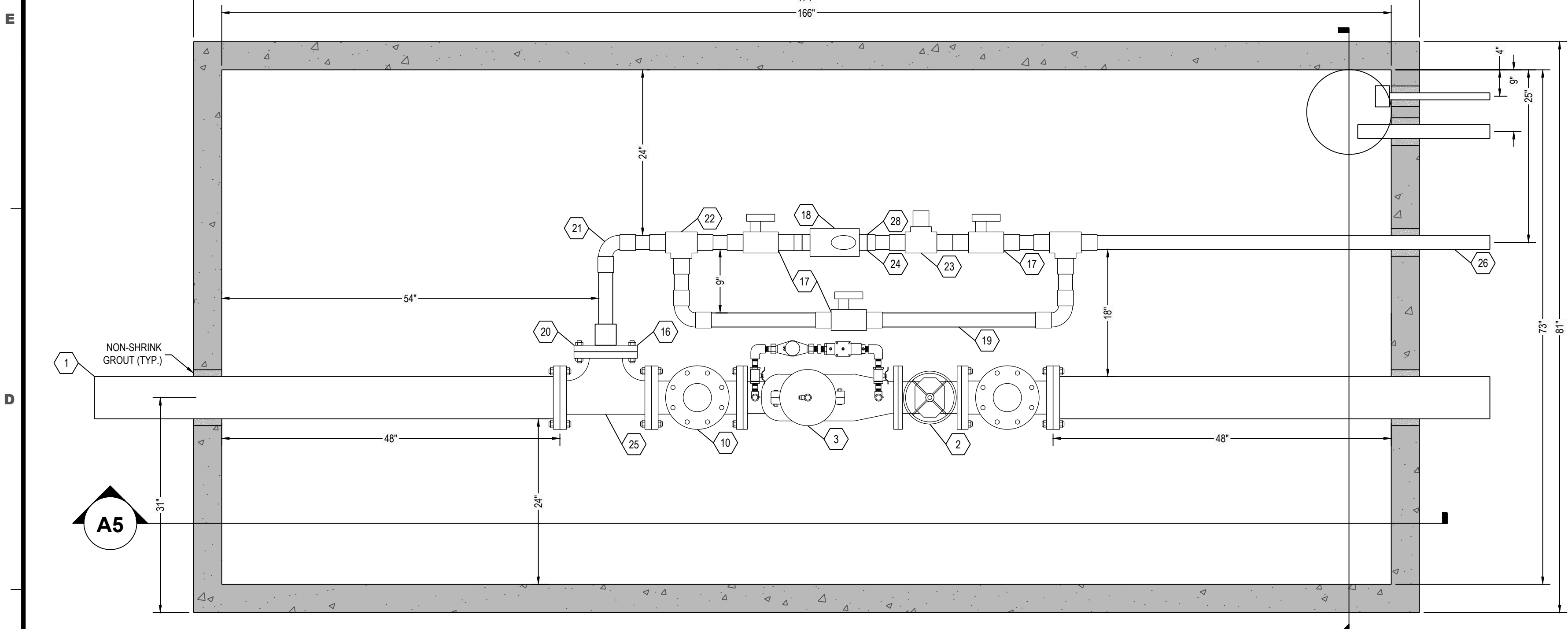

**C6 WATER METER VAULT TOP VIEW**  
1" = 1"

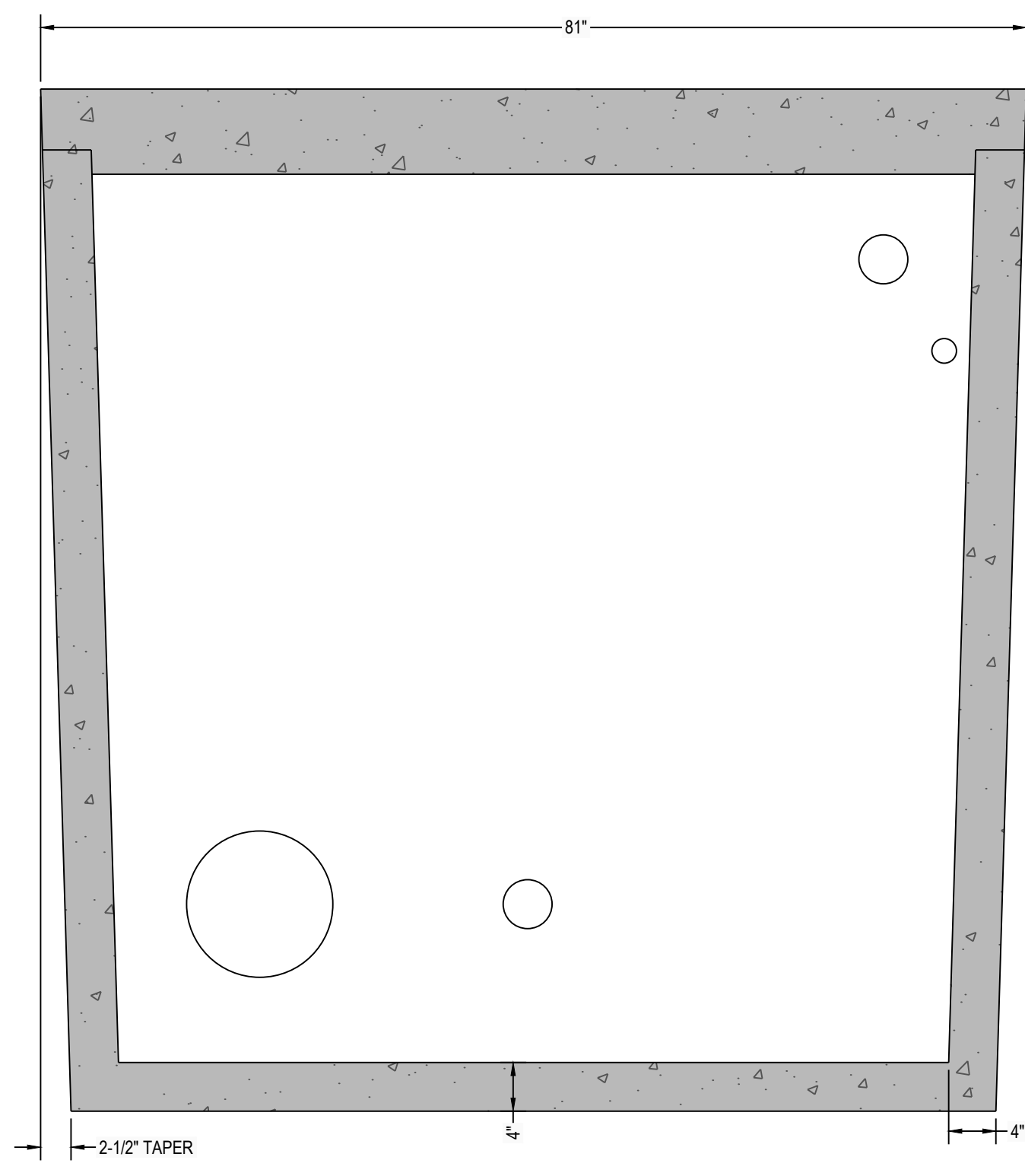

**C4 WATER METER VAULT SECTION VIEW**  
1" = 1"

**DESIGN DATA:**  
 1. EARTH COVER = 3 FEET MAX.  
 2. ALLOWABLE WHEEL LOAD = 2500 LB MAX.  
 3. CONCRETE MINIMUM COMPRESSIVE STRENGTH = 5,090 PSI @ 28 DAYS.  
 4. VAULT LID IS REINFORCED WITH 6 X 6 W8.0 X W8.0 WELDED WIRE FABRIC.  
 5. VAULT BOTTOM AND SIDES ARE REINFORCED WITH 6 X 6 W10.0 X W10.0 WELDED WIRE FABRIC.

**CASTING WEIGHTS:**  
 WEIGHT OF LID: 8,497.6 LBS  
 WEIGHT OF TANK: 17,222.8 LBS  
 TOTAL CASTING WEIGHT: 25,720.4 LBS

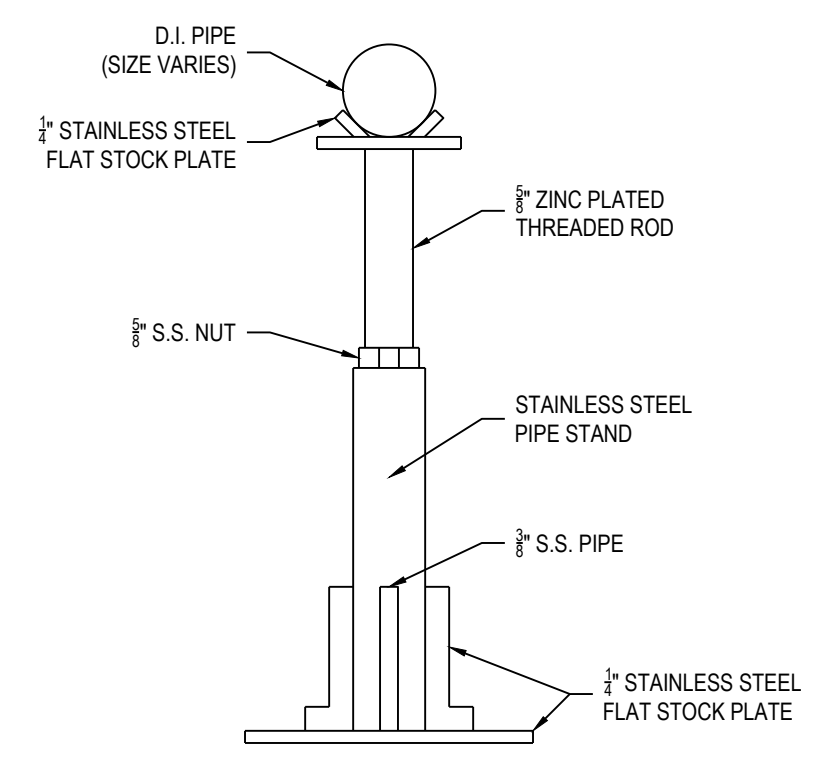

**D1 PIPE SUPPORT DETAIL**  
NTS

**H2O LOAD BEARING VAULTS ARE ALSO AVAILABLE INCLUDING LARGER HATCHES, GRADE RINGS, AND OTHER CUSTOM MODIFICATIONS THAT CAN BE MADE TO MEET JOB REQUIREMENTS, FOR ADDITIONAL CHARGES.**

**VAULTS CAN BE ORDERED: ASSEMBLED, UNASSEMBLED, OR WITH NO CONTENTS.**

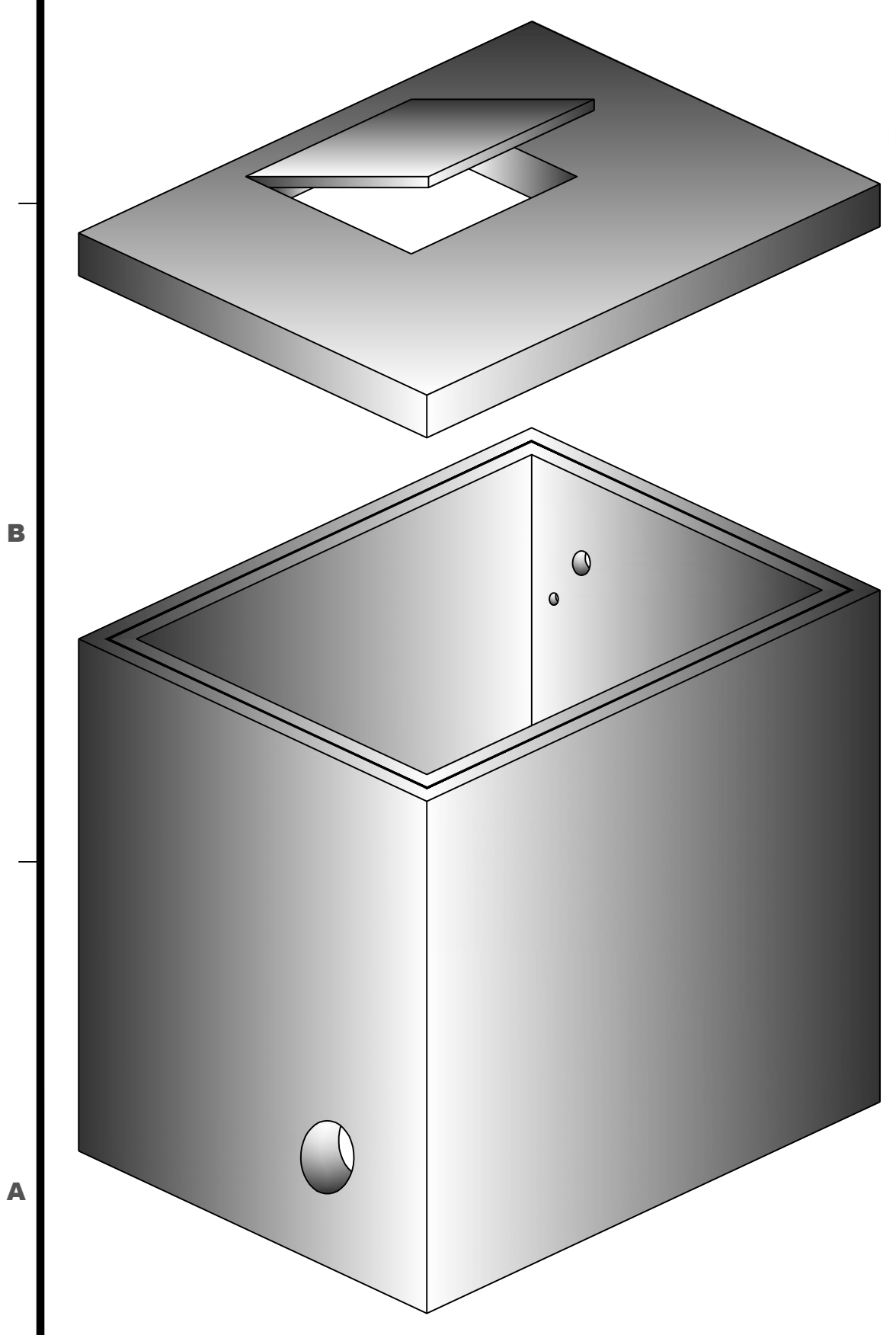

**A6 THREE DIMENSIONAL ISOMETRIC VIEW**  
NTS

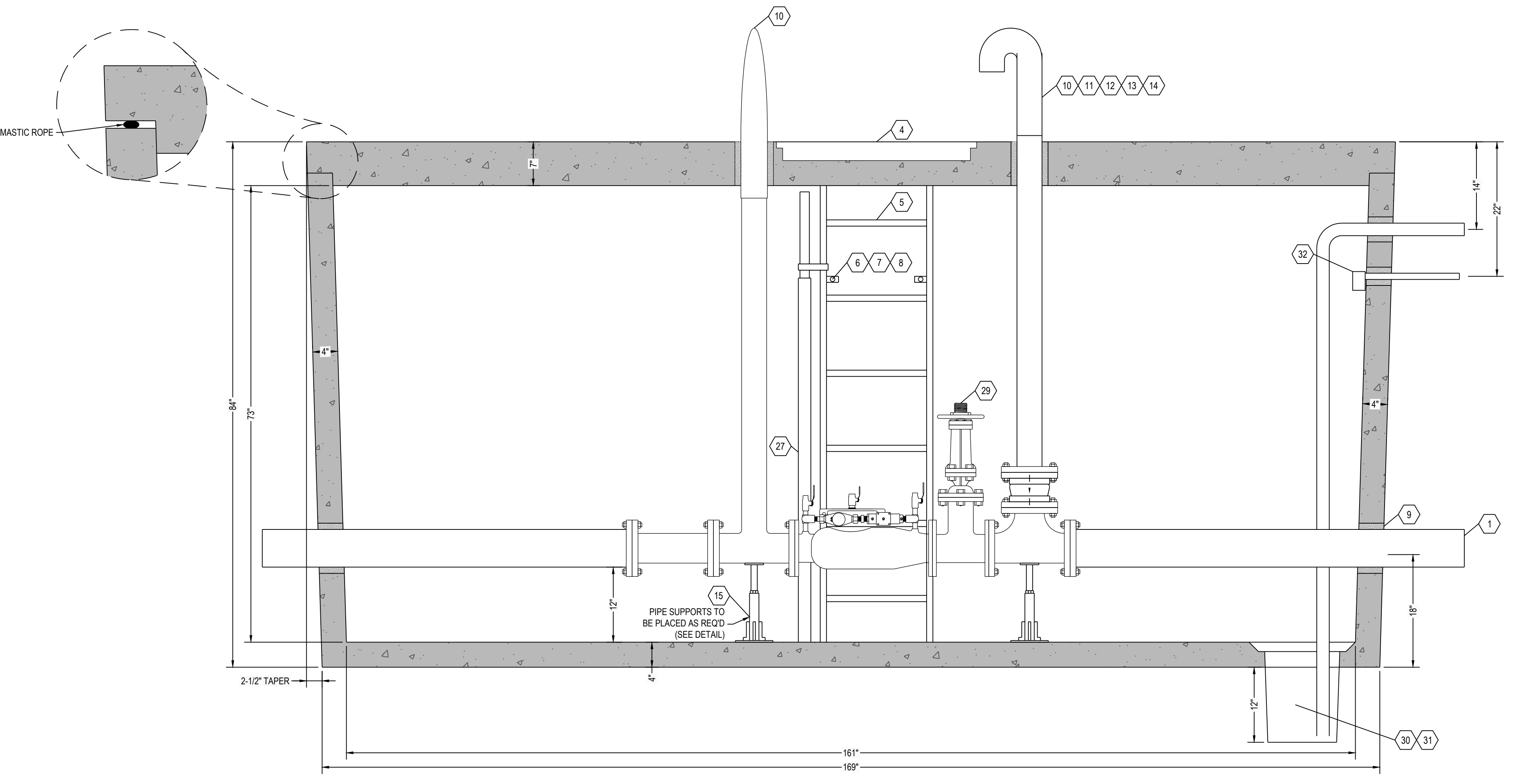

**A5 WATER METER VAULT SECTION VIEW**  
1" = 1"

ITEM	QTY	ITEM DESCRIPTION
1	2	6" X VARIES D.I. PIPE
2	2	6" DIA. OS&Y VALVE
3	1	6" DOUBLE CHK. ASSEMBLY, DETECTOR-AMES 3000SS
4	1	30" SQUARE ALUMINUM HATCH- SEE NOTES
5	1	6'-1" ALUMINUM LADDER- SEE NOTES
6	6	3/8" STAINLESS ANCHOR BOLT
7	7	3/8" STAINLESS WASHER
8	4	3/8" STAINLESS NUT
9	4	CORED HOLE, FILLED WITH GROUT
10	1	4" X 96" GALV SPOOL, MIP X FLG
11	1	4" GALV STREET 90
12	1	5" X 4" STORZ CONNECTION WITH CAP
13	1	4" WAFER CHECK VALVE
14	1	1/2" BRASS BALL DRIP
15	6	STAINLESS STEEL PIPE SUPPORT
16	4	2" BRASS COMP X MIPT COUPLER
17	4	2" BRASS CURB STOP FIP X FIP, LOCKING
18	1	2" DOMESTIC SERVICE METER (INSTALLED BY UTIL.)
19	VAR	2" HARD COPPER PIPING- TYPE K
20	1	4" X 2" REDUCING (BLIND) FLANGE
21	3	2" BRASS 90 DEG ELL
22	2	2" BRASS TEE, COMP X COMP X COMP
23	2	2" BRASS TEE, COMP X COMP X FIP W/ BRASS PLUG
24	2	BRONZE LOC PAK COUPLING (METER FLG X LOC PAK)
25	1	6" X 4" X 6" FLANGED D.I. TEE
26	1	2" COPPER STUBOUT
27	1	ALUMINUM USF TYPE LADDERUP SAFETY DEVICE
28	1	2" BRASS METER FLANGE, COMP X MTR FLNG
29	1	OS&Y TAMPER SWITCH
30	1	SUMP PIT W/ GRATE, HDPE BY POLYLOK
31	1	SUMP PUMP ASSEMBLY W/ 1/3 HP, 115 VOLT, 1 PH ZOELLER M153 AUTOMATIC PUMP, BALL CHECK VALVE, BALL VALVE, UNION TYPE DISCONNECT
32	1	ELECTRICAL JUNCTION BOX

**NOTES**  
 HATCH TO BE 30" X 30" ALUMINUM HATCH, 300 PSF, SINGLE DOOR, INCLUDING ANGLE FRAME, STAINLESS STEEL NUTS & BOLTS, STAINLESS STEEL HINGES, STAINLESS STEEL AUTOMATIC HOLD-OPEN ARM WITH RED VINYL GRIP, FLUSH LIFT HANDLE, TAMPER PROOF FASTENERS, AND EXPOSED PADLOCK STAPLE.  
 LADDER TO BE O.S.H.A. COMPLIANT ALUMINUM FLOORWALL MOUNT LADDER FABRICATED FROM 1 3/8" X 2 1/2" FLAT BARS AND 1 5/8" SQUARE EXTRUDED RUNGS, WITH SLIP RESISTANT RUNGS 12" ON CENTER, 18" WIDE WITH STANDARD MINIMUM 7" OFFSET MOUNTED WITH STAINLESS STEEL ANCHORS AND BOLTS.

# RENSELAER SEPTIC TANKS

1211 NORTH WESTON STREET  
 P.O. BOX 70  
 RENSELAER, INDIANA 47978  
 phone: (219) 866-5063  
 (800) 240-5123  
 fax: (219) 866-3894

**PROJECT NAME**  
**CLIENT NAME**  
**ADDRESS**

PROJECT NO: **08012**  
 FILE: 3000 GAL TR WATER VAULT.DWG  
 DRAWN BY: TVL  
 CHECKED BY: PEW

TITLE:  
**MANUFACTURER'S DETAIL DRAWING**  
 3000 GALLON WATER METER VAULT  
 TRAFFIC RATED

**R-000**

**\* ALL RENSELAER SEPTIC TANKS ARE MONOLITHICALLY Poured \***

This drawing is the property of Rensselaer Septic Tanks. It is submitted for reference purposes only. © 2008 Rensselaer Septic Tanks