

6

5

4

3

2

1

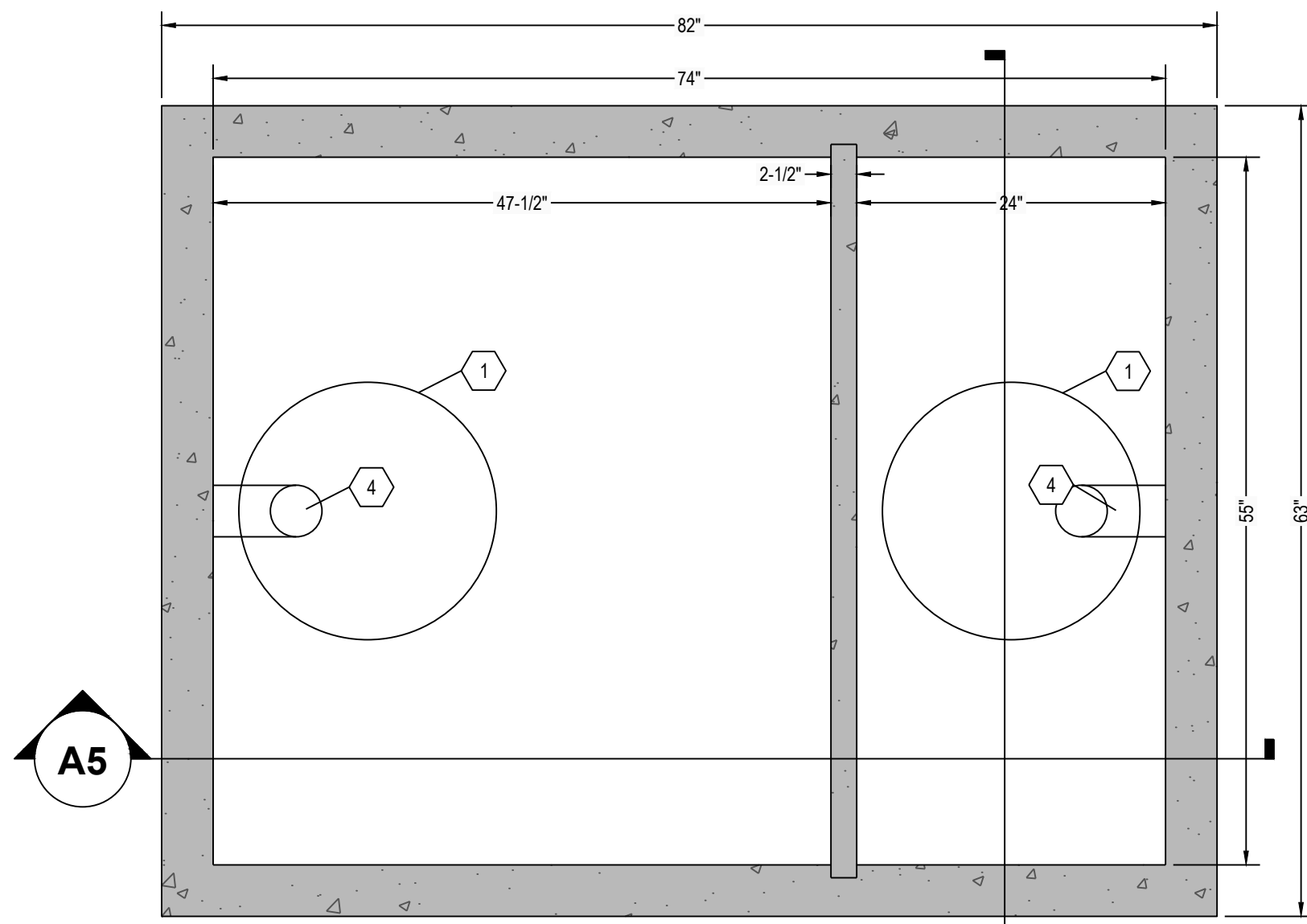

**C6 SEPTIC TANK TOP VIEW**  
1" = 1"

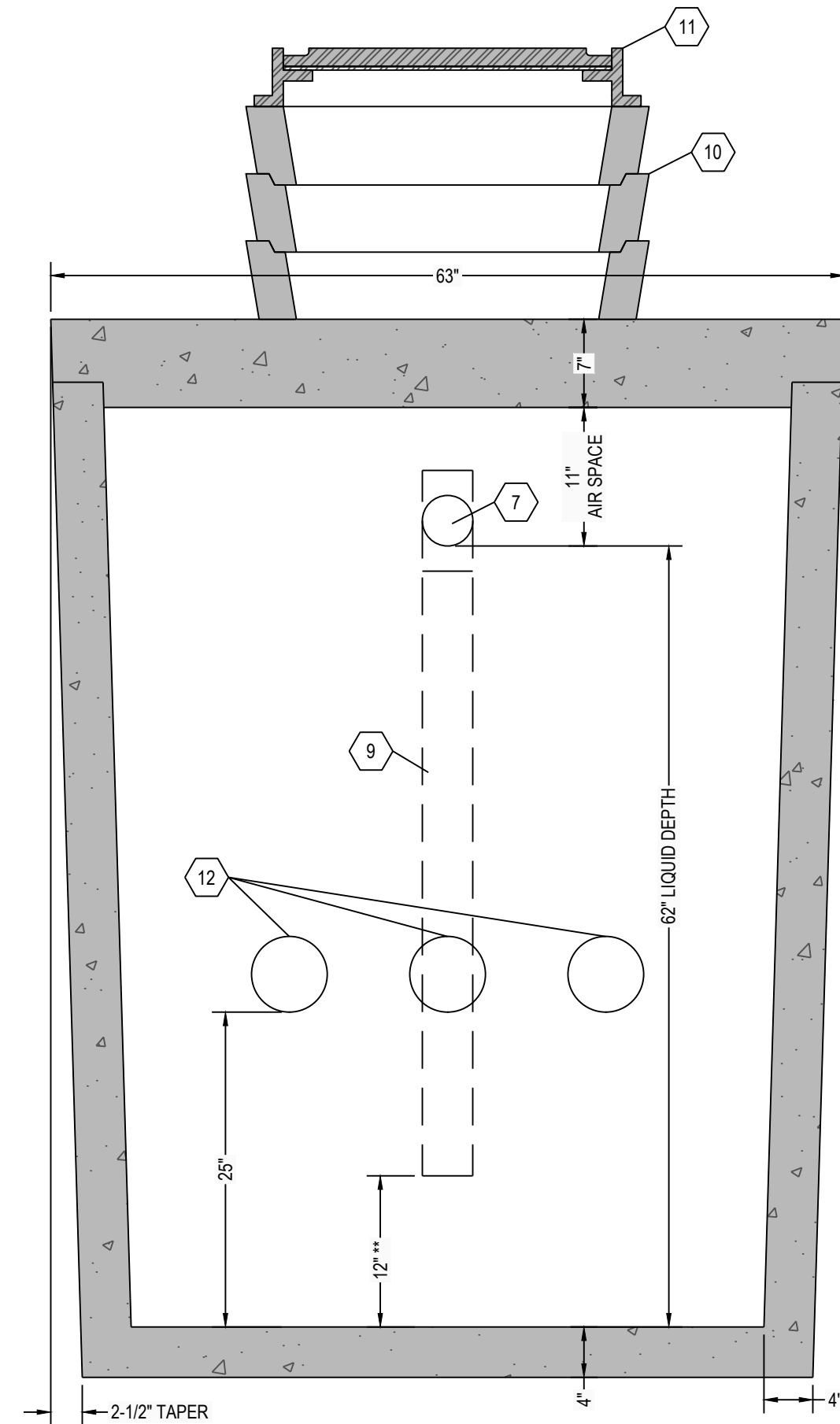

**C4 SEPTIC TANK TOP VIEW**  
1" = 1"

\*\* DISTANCE MAY BE INCREASE OR DECREASED BASED UPON WASTE FLOWS.

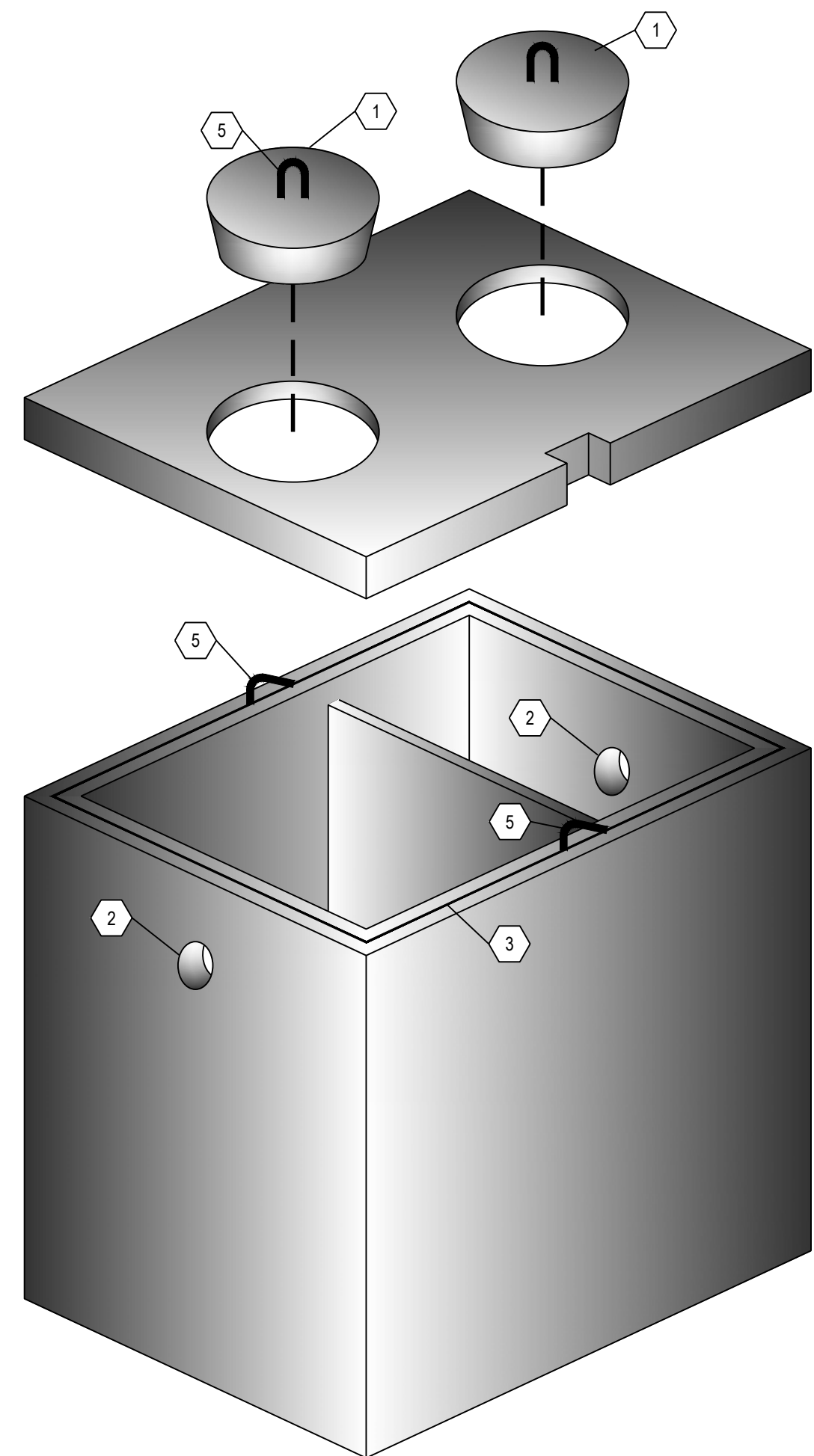

**A6 THREE DIMENSIONAL ISOMETRIC VIEW**  
NTS

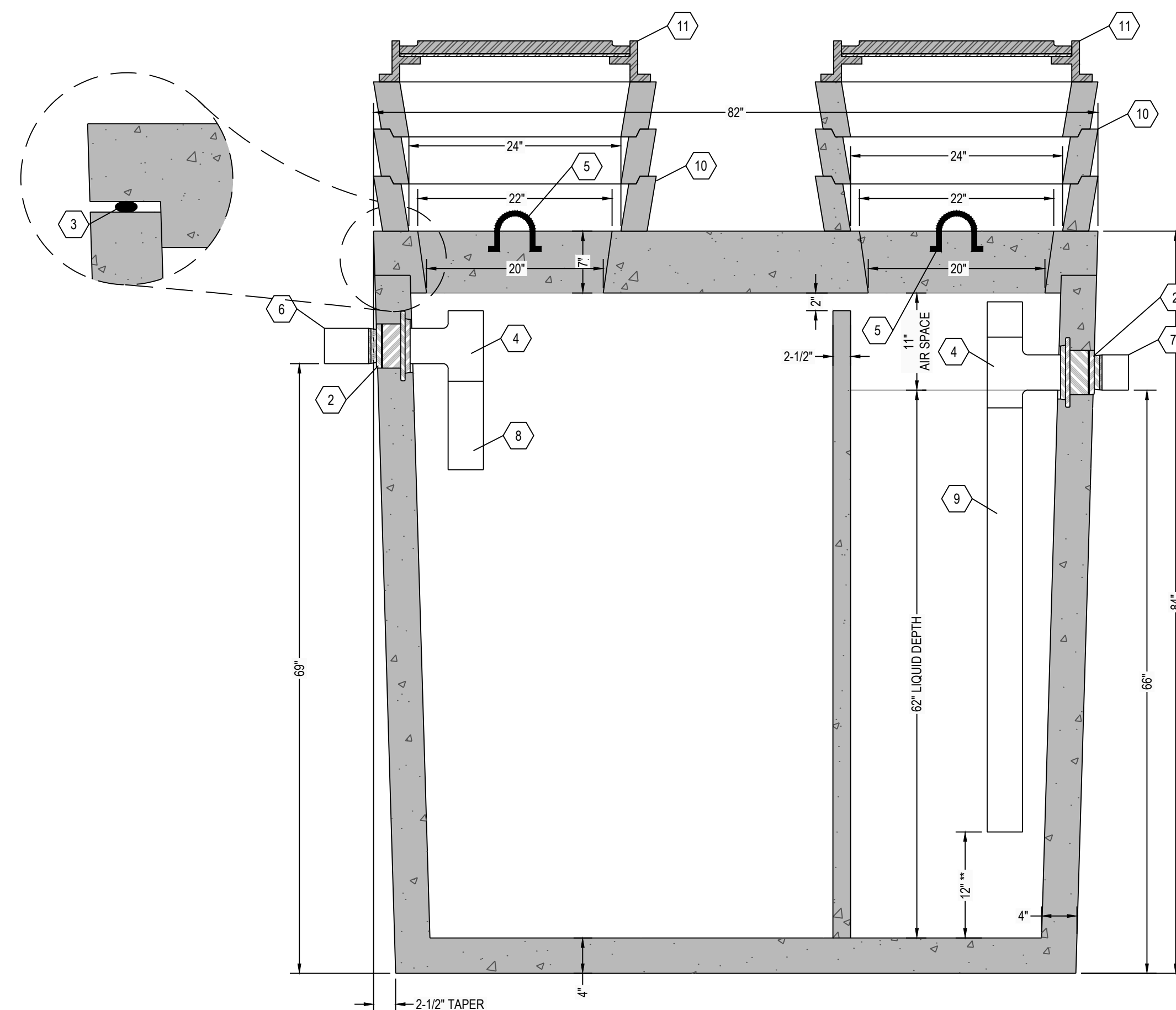

**A5 SEPTIC TANK SECTION VIEW**  
1" = 1"

\*\* DISTANCE MAY BE INCREASE OR DECREASED BASED UPON WASTE FLOWS.

**NOTE:**  
24" DIAMETER POLY RISERS & LIDS OR CUSTOM RECTANGULAR RISERS WITH ALUMINUM HATCHES ARE AVAILABLE AS SUBSTITUTES TO CONCRETE GRADE RINGS AS SHOWN HEREON.

**DESIGN DATA:**

1. EARTH COVER = 5 FEET MAX
2. ALLOWABLE WHEEL LOAD = 8000 LB MAX
3. CONCRETE MINIMUM COMPRESSIVE STRENGTH = 5,000 PSI @ 28 DAYS
4. LIFTING HOOKS ARE 3/4" DIAMETER, ASTM A36 COLD ROLLED STEEL
5. SEPTIC TANK LID IS REINFORCED WITH #3 REBAR SPACED AT 12" OC GRID
6. SEPTIC TANK BOTTOM AND SIDES ARE REINFORCED WITH 6 X 6 W8.0 X W8.0 WELDED WIRE FABRIC.
7. ALL CONCRETE SURFACES ABOVE THE LIQUID LEVEL ARE COATED WITH AIRLESS ASPHALT.

**CASTING WEIGHTS**

WEIGHT OF LID: 3,043.9 LBS  
 WEIGHT OF TANK: 8,493.5 LBS  
 TOTAL CASTING WEIGHT: 11,537.4 LBS

**(2) COMPARTMENT TANK CAPACITY:**

FIRST COMPARTMENT CAPACITY = 655 GALLONS  
 10.6 GALLONS PER INCH

SECOND COMPARTMENT CAPACITY = 339 GALLONS  
 5.5 GALLONS PER INCH

STORAGE CAPACITY = 999 GALLONS  
 TOTAL VOLUME = 1198 GALLONS

**KEYNOTE INDEX**

1	20" DIAMETER MANHOLE OPENING
2	HIGH PRESSURE CLOSED END BOOT SEAL
3	MASTIC ROPE
4	SANITARY TEE AT INLET & OUTLET
5	3/4" DIAMETER LIFTING HOOKS
6	6" DIAMETER INLET
7	6" DIAMETER OUTLET
8	12" EXTENSION AT INLET
9	DROP TO WITHIN 12" OF THE FLOOR **
10	CONCRETE GRADE RING (AS NECESSARY)
11	CAST FRAME & COVER (NOT INCLUDED)
12	THREE (3) 6" DIAMETER HOLES THROUGH INTERIOR WALL

# RENSELAER SEPTIC TANKS

1211 NORTH WESTON STREET  
 P.O. BOX 70  
 RENSELAER, INDIANA 47978  
 phone: (219) 866-5063  
 (800) 240-5123  
 fax: (219) 866-3894

PROJECT NAME  
 CLIENT NAME  
 ADDRESS

PROJECT NO: ---  
 FILE: 1000 GAL- DUAL- TR-GR-GT.DWG  
 DRAWN BY: ASJM  
 CHECKED BY: PEW

TITLE:  
**MANUFACTURER'S  
 DETAIL DRAWING**  
 1000 GALLON (2) COMPARTMENT  
 TRAFFIC RATED

**R-000**

\* ALL RENSELAER SEPTIC TANKS ARE MONOLITHICALLY Poured \*