

6

5

4

3

2

1

E

D

C

B

A

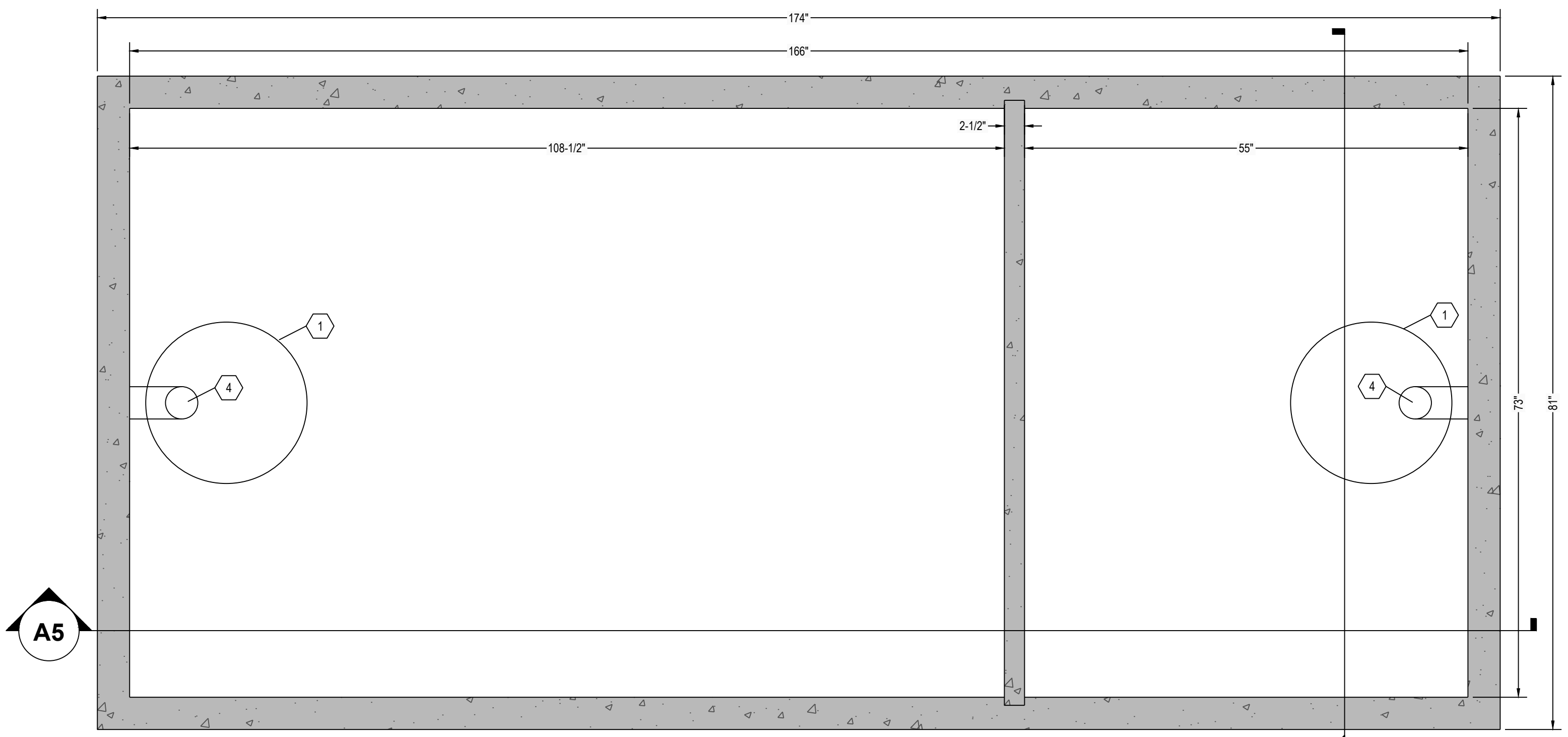

C5 SEPTIC TANK TOP VIEW
1" = 1"

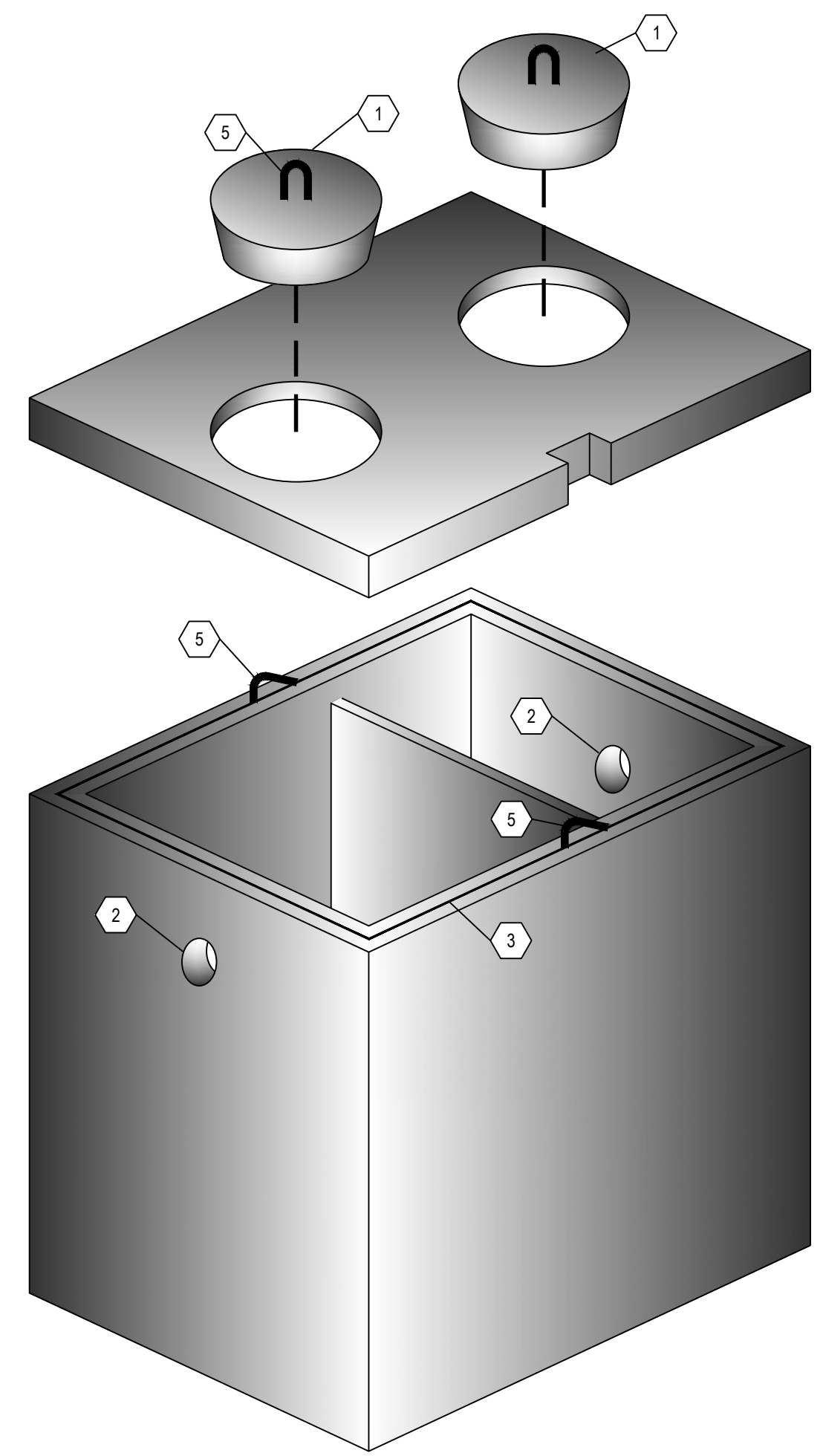

A6 THREE DIMENSIONAL ISOMETRIC VIEW
NTS

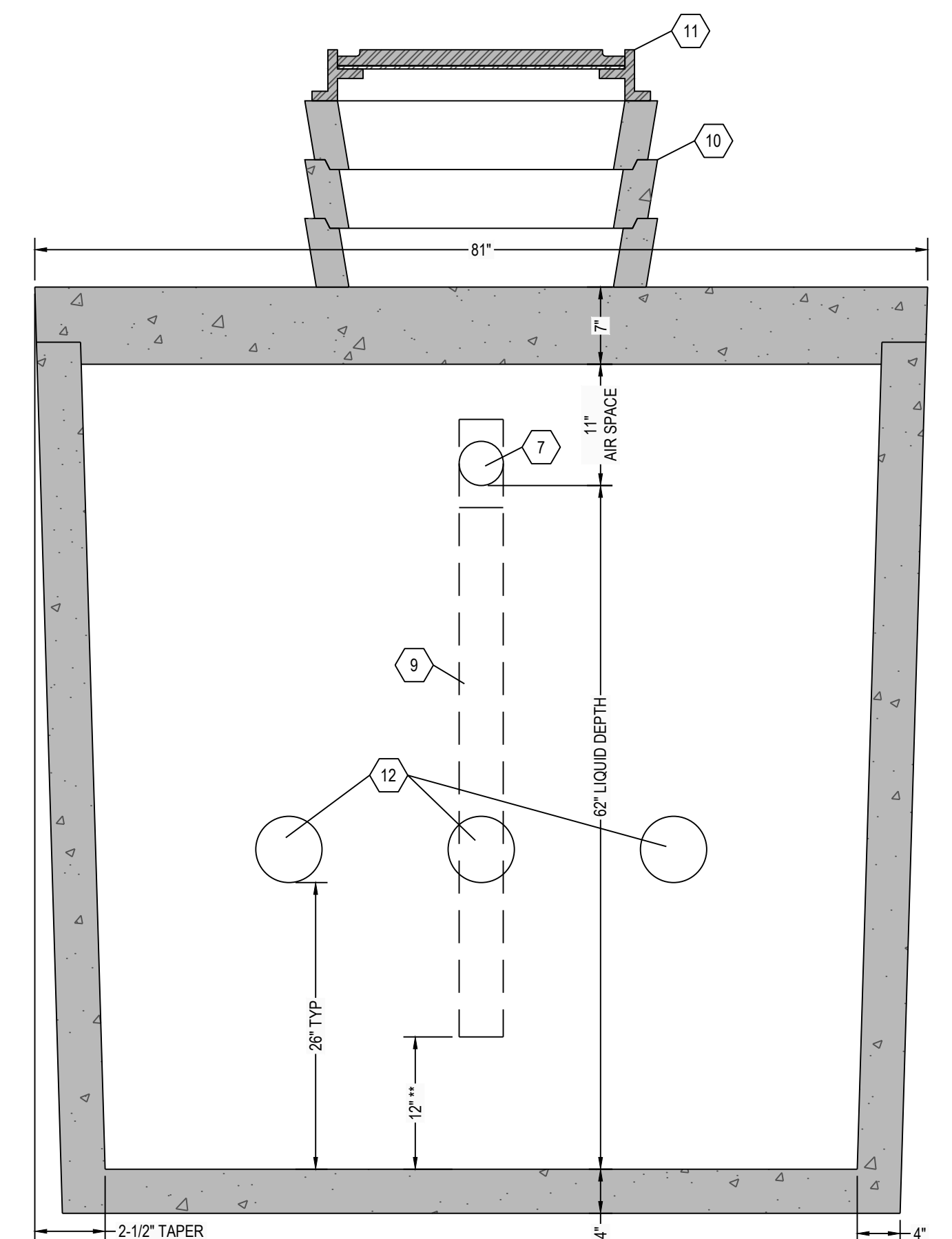

C3 SEPTIC TANK SECTION VIEW
1" = 1"

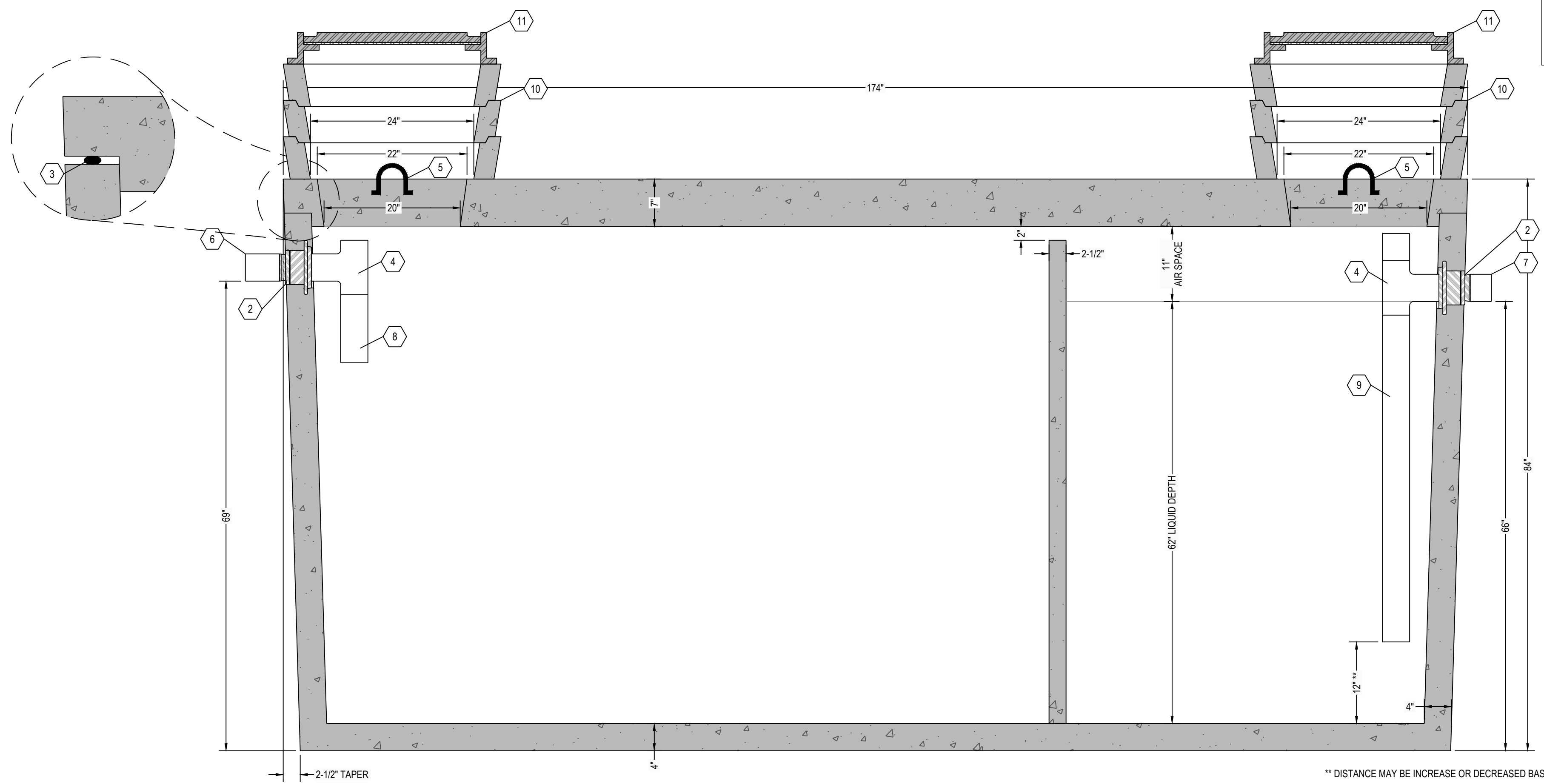

A5 SEPTIC TANK SECTION VIEW
1" = 1"

DESIGN DATA:

1. EARTH COVER = 5 FEET MAX
2. ALLOWABLE WHEEL LOAD = 8000 LB MAX
3. CONCRETE MINIMUM COMPRESSIVE STRENGTH = 5,000 PSI @ 28 DAYS
4. LIFTING HOOKS ARE 1/2" DIAMETER, ASTM A36 COLD ROLLED STEEL
5. SEPTIC TANK LID IS REINFORCED WITH #3 REBAR SPACED AT 12" OC GRID.
6. SEPTIC TANK BOTTOM AND SIDES ARE REINFORCED WITH 6 X 6 W8.0 X W8.0 WELDED WIRE FABRIC.
7. ALL CONCRETE SURFACES ABOVE THE LIQUID LEVEL ARE COATED WITH AIRLESS ASPHALT.

CASTING WEIGHTS

WEIGHT OF LID: 8,497.6 LBS
 WEIGHT OF TANK: 17,222.8 LBS
 TOTAL CASTING WEIGHT: 25,720.4 LBS

(2) COMPARTMENT TANK CAPACITY:

FIRST COMPARTMENT CAPACITY = 2026 GALLONS
 32.7 GALLONS PER INCH
 SECOND COMPARTMENT CAPACITY = 1006 GALLONS
 16.2 GALLONS PER INCH
 STORAGE CAPACITY = 3032 GALLONS
 TOTAL VOLUME = 3895 GALLONS

** DISTANCE MAY BE INCREASE OR DECREASED BASED UPON WASTE FLOWS.

NOTE:
 24" DIAMETER POLY RISERS & LIDS OR CUSTOM RECTANGULAR RISERS WITH ALUMINUM HATCHES ARE AVAILABLE AS SUBSTITUTES TO CONCRETE GRADE RINGS AS SHOWN HEREON.

KEYNOTE INDEX

1	20" DIAMETER MANHOLE OPENING
2	HIGH PRESSURE CLOSED END BOOT SEAL
3	MASTIC ROPE
4	SANITARY TEE AT INLET & OUTLET
5	1/2" DIAMETER LIFTING HOOKS
6	6" DIAMETER INLET
7	6" DIAMETER OUTLET
8	12" EXTENSION AT INLET
9	DROP TO WITHIN 12" OF THE FLOOR **
10	CONCRETE GRADE RING (AS NECESSARY)
11	CAST FRAME & COVER (NOT INCLUDED)
12	THREE (3) 6" DIAMETER HOLES THROUGH INTERIOR WALL

*** ALL RENSSELAER SEPTIC TANKS ARE MONOLITHICALLY Poured ***

RENSSELAER SEPTIC TANKS

1211 NORTH WESTON STREET
 P.O. BOX 70
 RENSSELAER, INDIANA 47978
 phone: (219) 866-5063
 (800) 240-5123
 fax: (219) 866-3894

PROJECT NAME
 CLIENT NAME
 ADDRESS

PROJECT NO: ---
 FILE: 3000 GAL- DUAL- TR-GR-GT.DWG
 DRAWN BY: ASJM
 CHECKED BY: PEW
 TITLE:
MANUFACTURER'S DETAIL DRAWING
 3000 GALLON (2) COMPARTMENT TRAFFIC RATED

R-000

This drawing is the property of Rensselaer Septic Tanks. It is submitted for reference purposes only. © 2008 Rensselaer Septic Tanks