

6

5

4

3

2

1

E

D

C

B

A

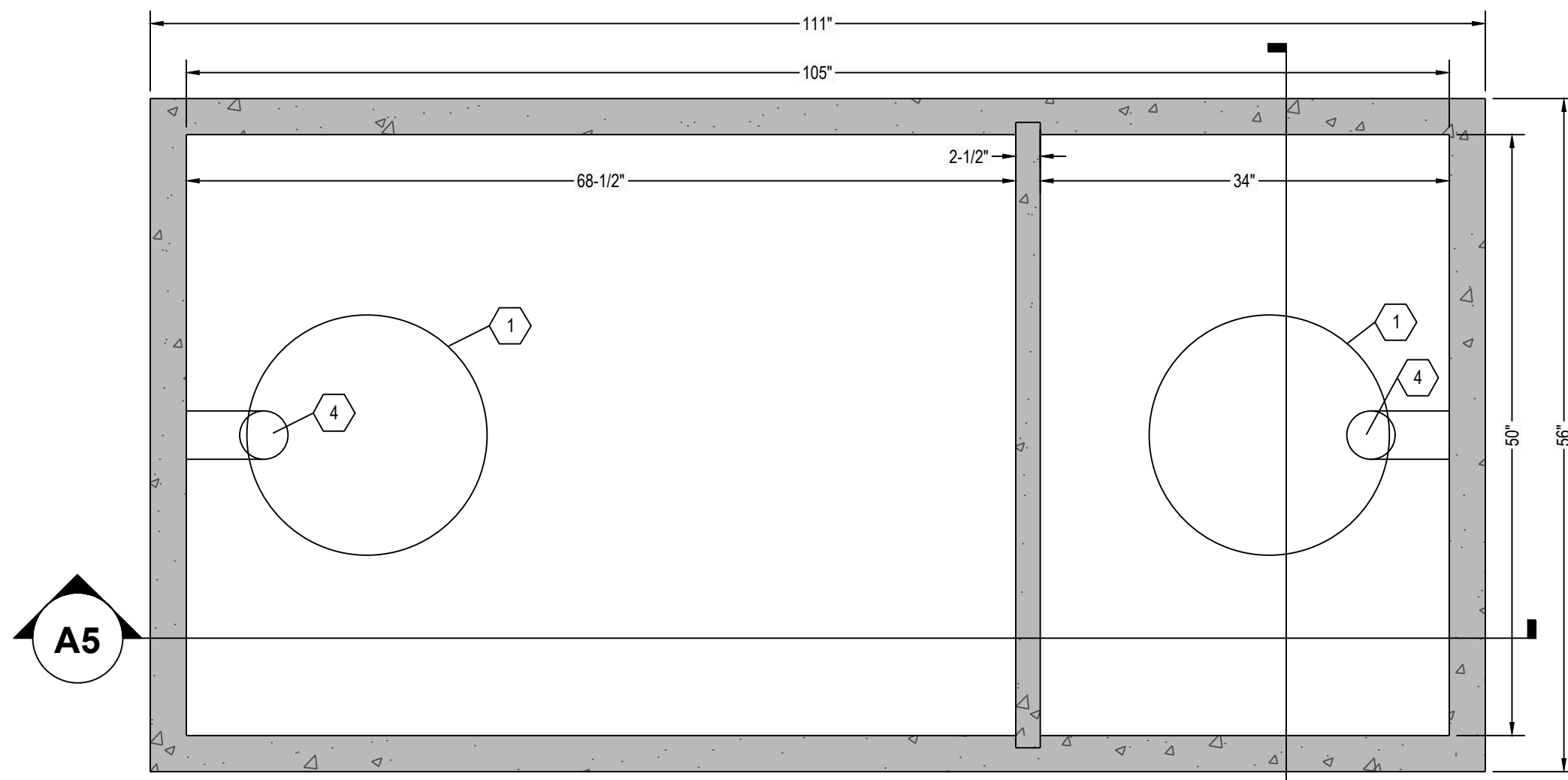

C6 SEPTIC TANK TOP VIEW
1" = 1"

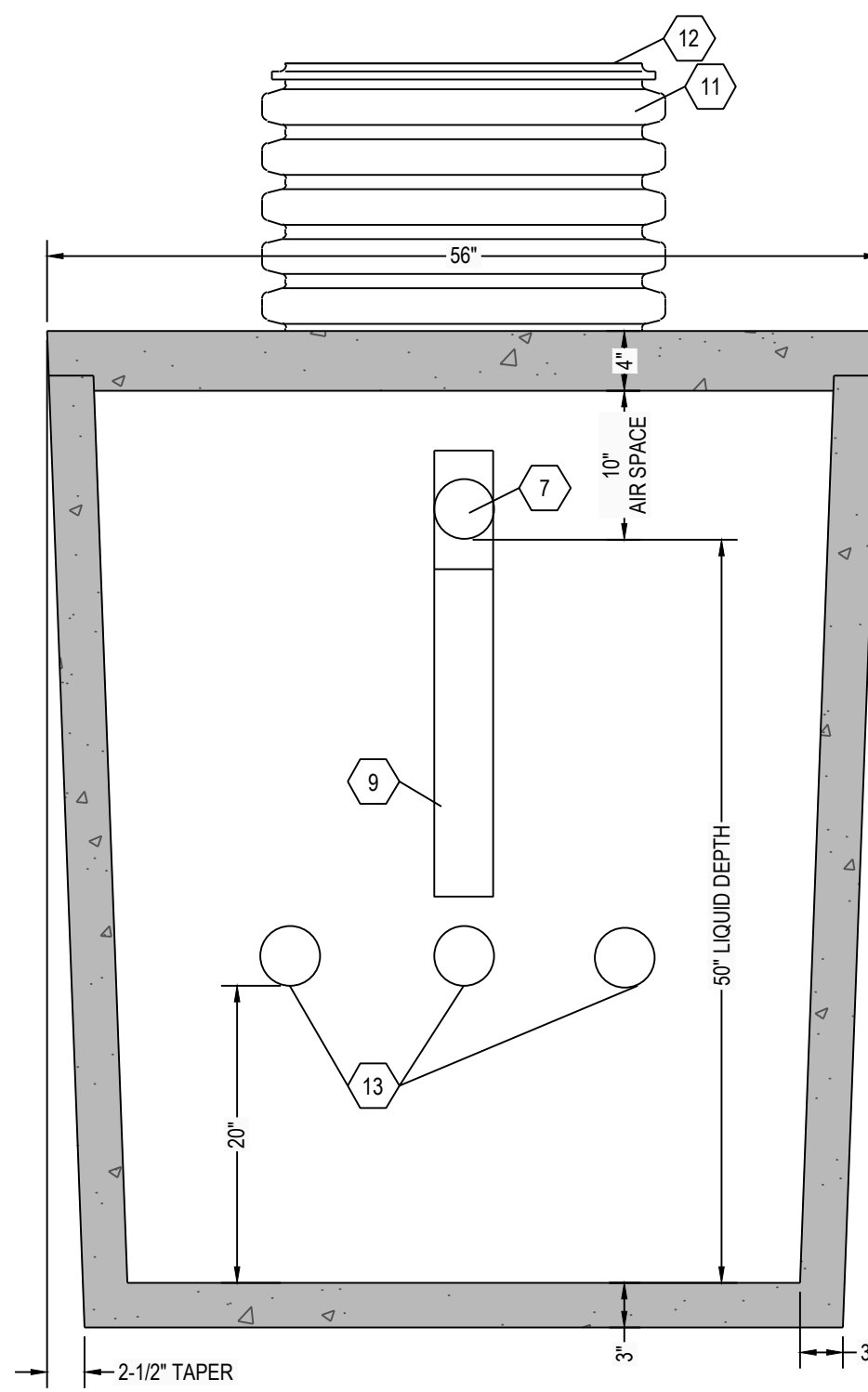

C4 SEPTIC TANK SECTION VIEW
1" = 1"

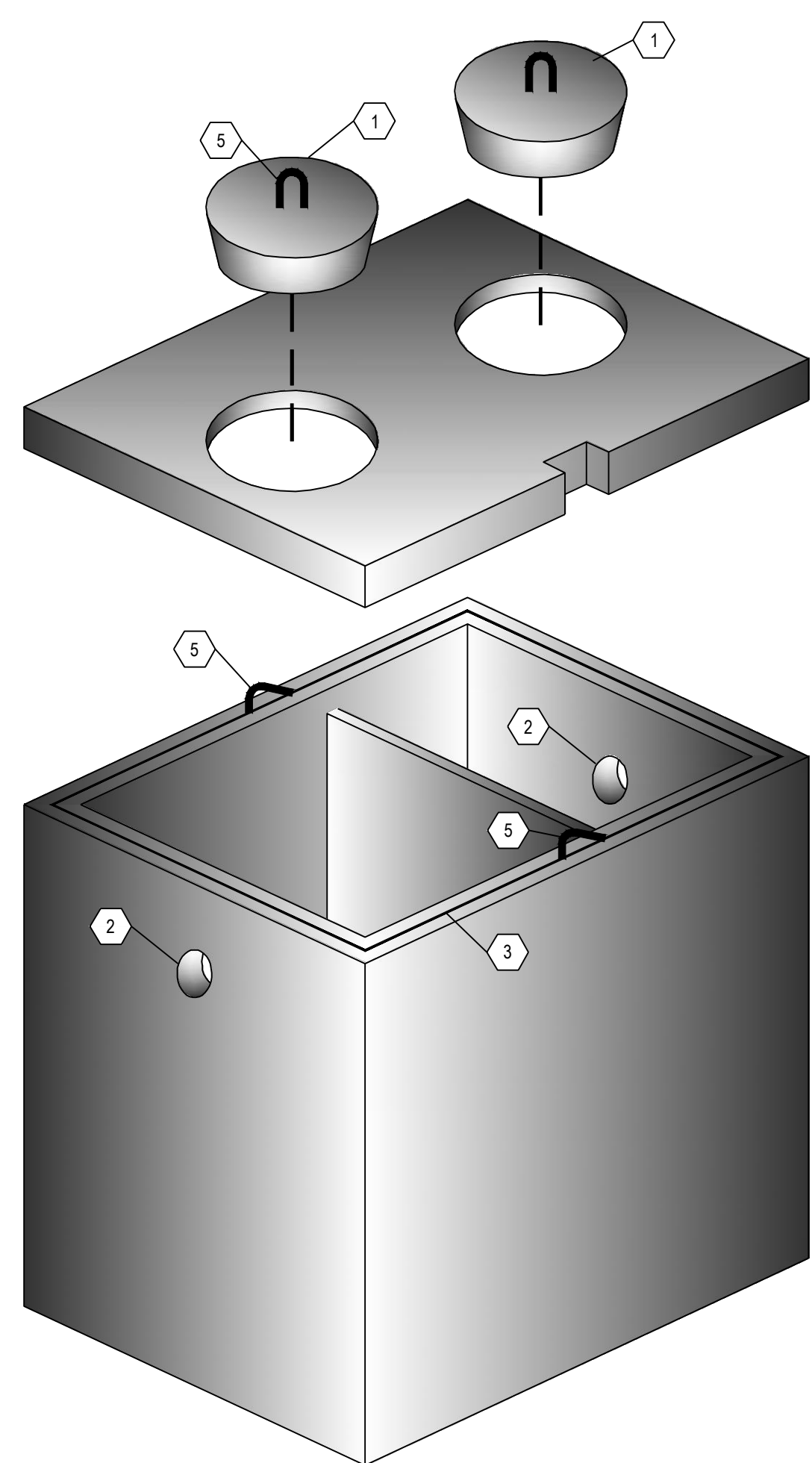

A6 THREE DIMENSIONAL ISOMETRIC VIEW
NTS

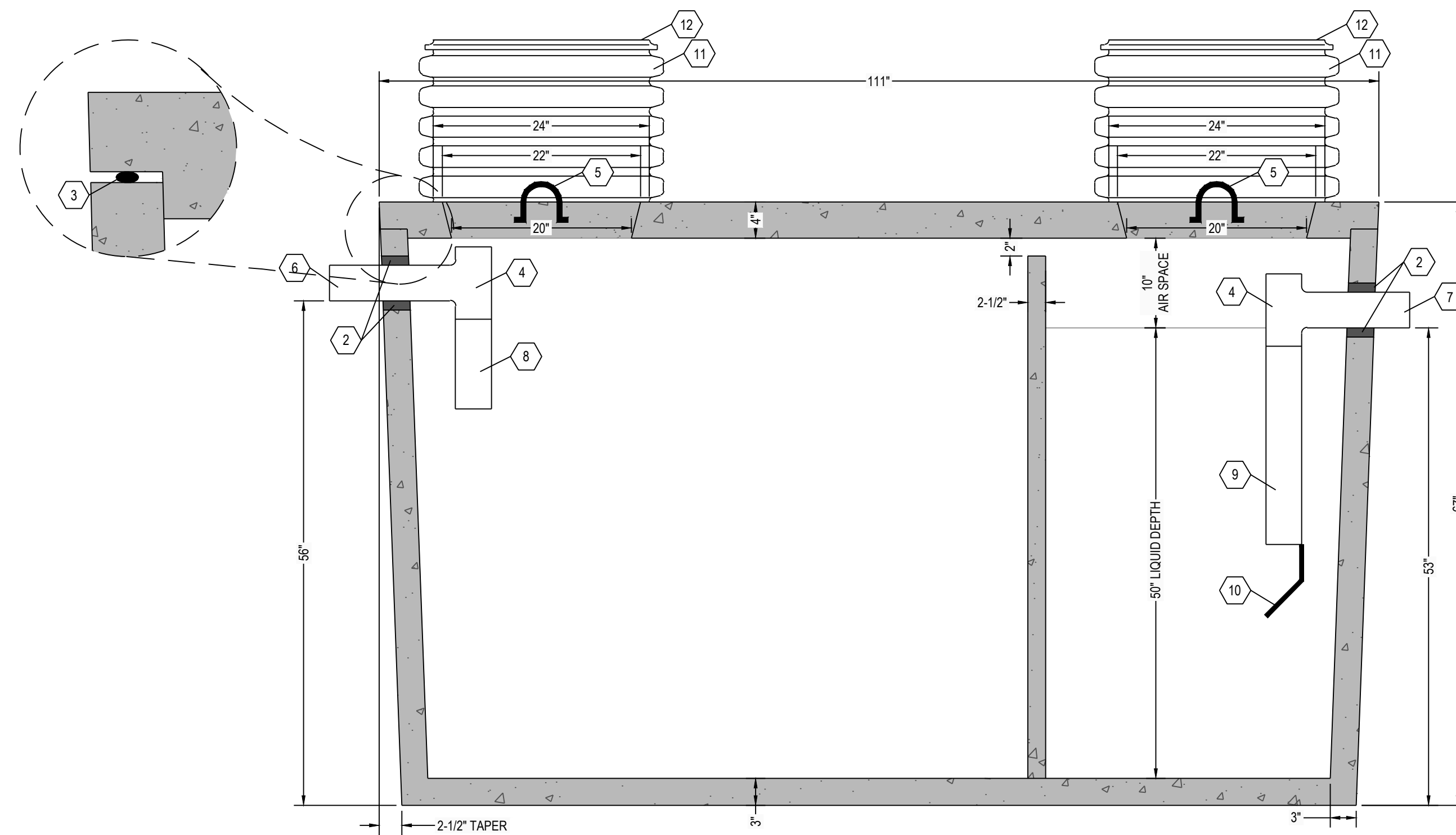

A5 SEPTIC TANK SECTION VIEW
1" = 1"

NOTE:
1. EXTENSIONS ARE AVAILABLE FOR 24" DIAMETER POLY RISERS
2. 24" DIAMETER CONCRETE GRADE RINGS OR CUSTOM RECTANGULAR RISERS WITH ALUMINUM HATCHES ARE AVAILABLE AS SUBSTITUTES TO POLY RISER AS SHOWN HEREON.
3. HIGH PRESSURE CLOSED END BOOT SEALS ARE AVAILABLE AS SUBSTITUTES TO RUBBER GASKET TYPE SEALS AS SHOWN HEREON.

DESIGN DATA:

- EARTH COVER = 3 FEET MAX.
- ALLOWABLE WHEEL LOAD = 2500 LB MAX.
- CONCRETE MINIMUM COMPRESSIVE STRENGTH = 5,090 PSI @ 28 DAYS
- LIFTING HOOKS ARE 1/2" DIAMETER, ASTM A36 COLD ROLLED STEEL
- SEPTIC TANK LID IS REINFORCED WITH 6 X 6 W8.0 X W8.0 WELDED WIRE FABRIC.
- SEPTIC TANK BOTTOM AND SIDES ARE REINFORCED WITH 6 X 6 W10.0 X W10.0 WELDED WIRE FABRIC.
- ALL CONCRETE SURFACES ABOVE THE LIQUID LEVEL ARE COATED WITH AIRLESS ASPHALT.

CASTING WEIGHTS

WEIGHT OF LID: 2,074.5 LBS
WEIGHT OF TANK: 6,468.9 LBS
TOTAL CASTING WEIGHT: 8,543.4 LBS

COMPARTMENT TANK CAPACITY:

FIRST COMPARTMENT CAPACITY = 674 GALLONS
13.5 GALLONS PER INCH

SECOND COMPARTMENT CAPACITY = 323 GALLONS
6.5 GALLONS PER INCH

STORAGE CAPACITY = 997 GALLONS
TOTAL VOLUME = 1265 GALLONS

KEYNOTE INDEX

1	20" DIAMETER MANHOLE OPENING
2	HIGH PRESSURE CLOSED END BOOT SEAL
3	MASTIC ROPE
4	SANITARY TEE AT INLET & OUTLET
5	1/2" DIAMETER LIFTING HOOKS
6	4" DIAMETER INLET (6" AVAILABLE UPON REQUEST)
7	4" DIAMETER OUTLET (6" AVAILABLE UPON REQUEST)
8	12" EXTENSION AT INLET
9	24" EXTENSION AT OUTLET
10	FLEXIBLE, NON-CORROSIVE POLYPROPYLENE GAS BAFFLE BY TUF-TITE AFFIXED WITH STAINLESS STEEL SCREWS
11	24" DIAMETER POLY RISER (18" HEIGHT TYP)
12	24" DIAMETER GAS TIGHT POLY SNAP CAP LID AFFIXED WITH STAINLESS STEEL SCREWS
13	THREE (3) 4" DIAMETER PORTS THROUGH INTERIOR WALL

RENSELAER SEPTIC TANKS

1211 NORTH WESTON STREET
P.O. BOX 70
RENSELAER, INDIANA 47978
phone: (219) 866-5063
(800) 240-5123
fax: (219) 866-3894

PROJECT NAME
CLIENT NAME
ADDRESS

PROJECT NO: _____
FILE: 1000 GAL - NT.DWG
DRAWN BY: ASJM
CHECKED BY: PEW

TITLE:
**MANUFACTURER'S
DETAIL DRAWING**
1000 GALLON (2) COMPARTMENT
NO TRAFFIC

R-000

* ALL RENSELAER SEPTIC TANKS ARE MONOLITHICALLY Poured *

This drawing is the property of Rensselaer Septic Tanks. It is submitted for reference purposes only. © 2008 Rensselaer Septic Tanks