

6

5

4

3

2

1

E

D

C

B

A

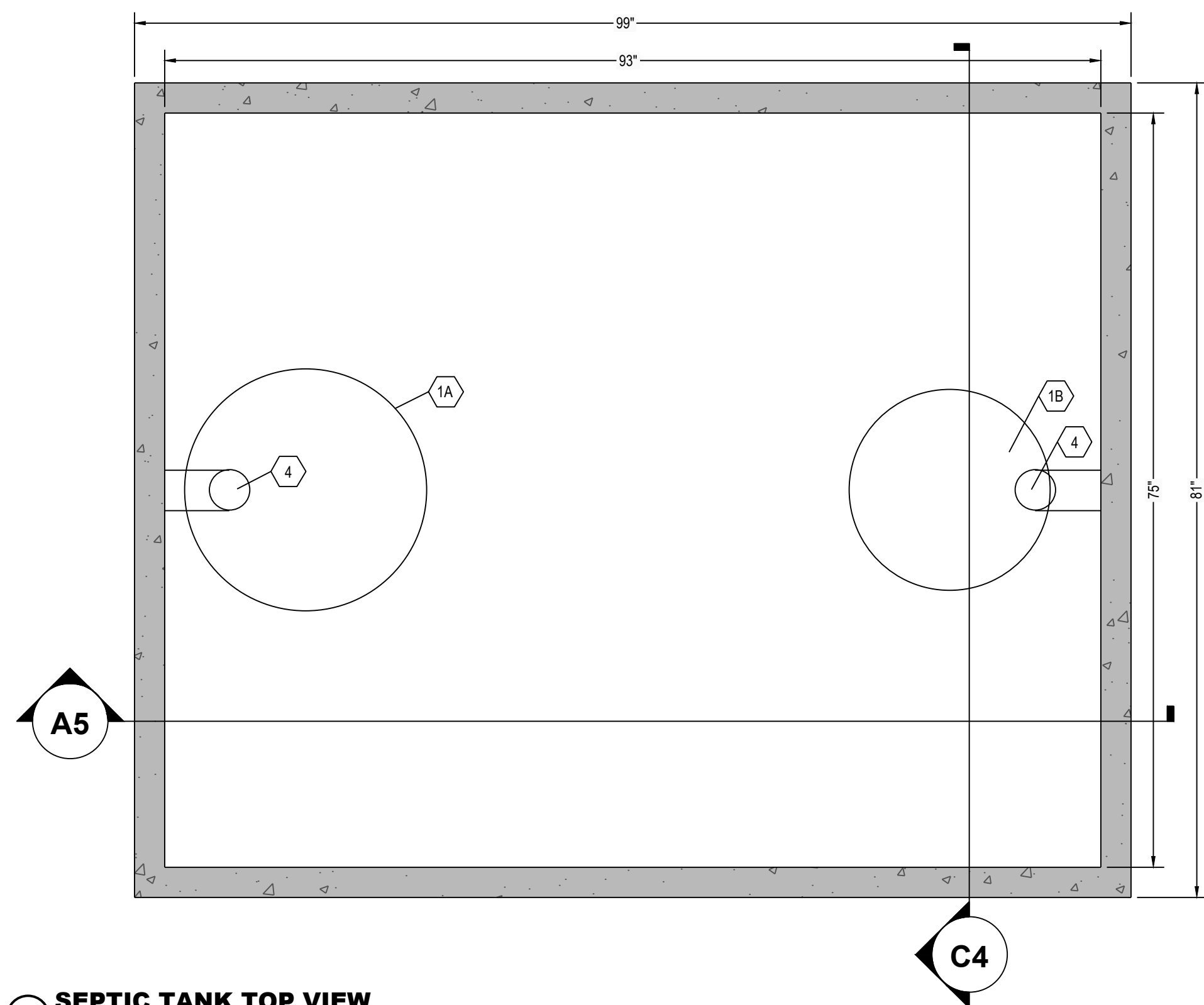

C6 SEPTIC TANK TOP VIEW
1" = 1"

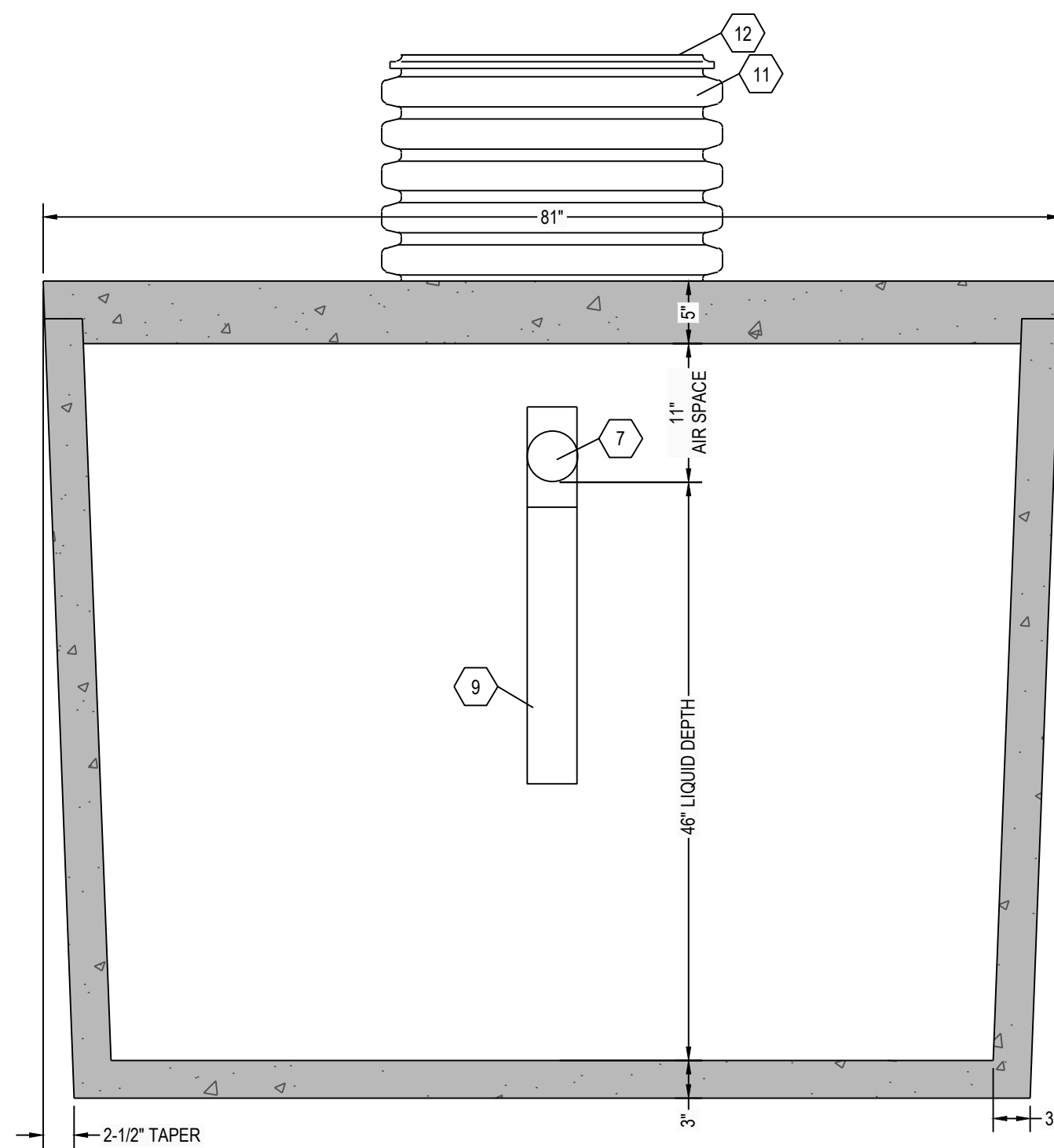

C4 SEPTIC TANK SECTION VIEW
1" = 1"

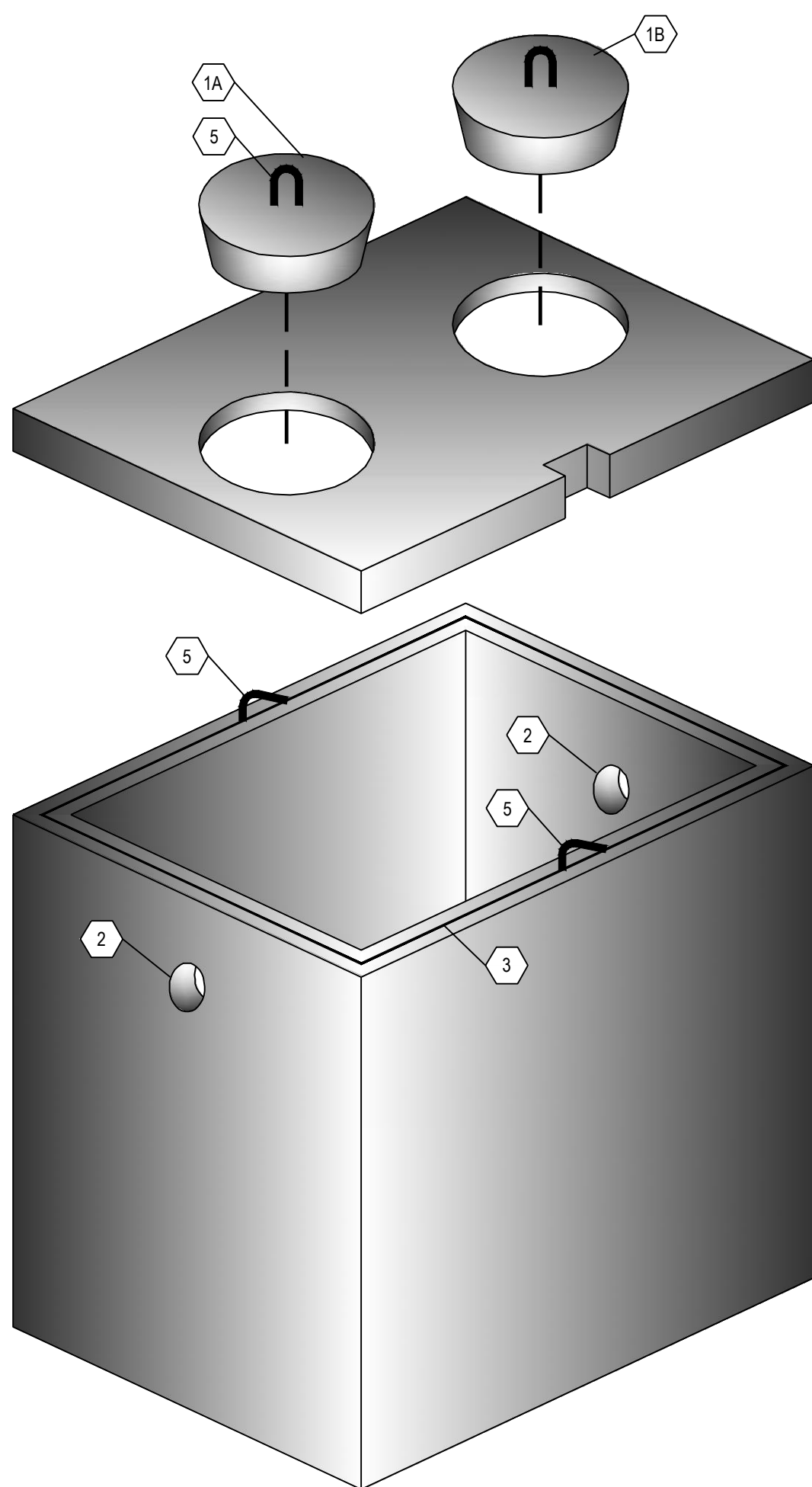

A6 THREE DIMENSIONAL ISOMETRIC VIEW
NTS

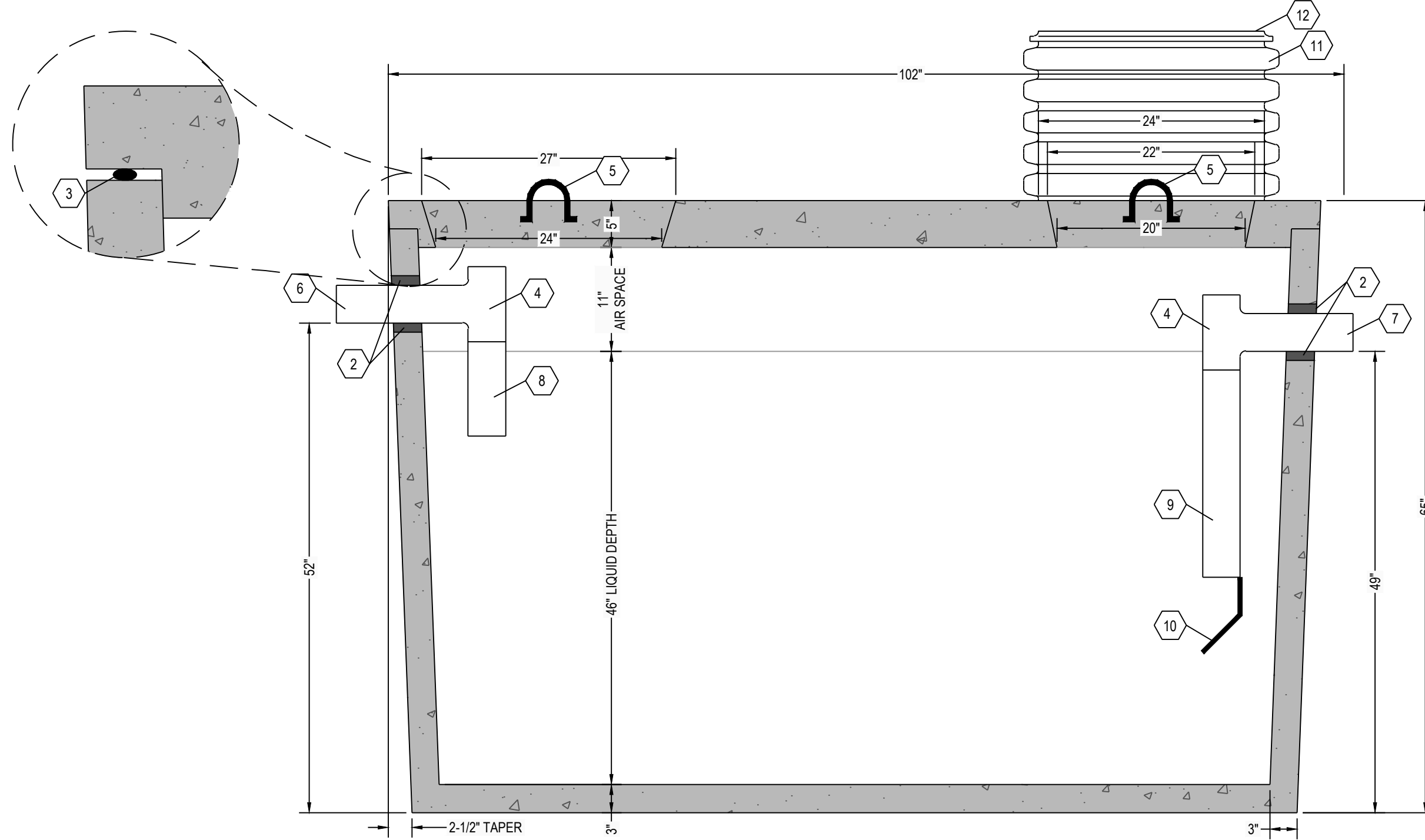

A5 SEPTIC TANK SECTION VIEW
1" = 1"

DESIGN DATA:

1. EARTH COVER = 3 FEET MAX.
2. ALLOWABLE WHEEL LOAD = 2500 LB MAX
3. CONCRETE MINIMUM COMPRESSIVE STRENGTH = 5,090 PSI @ 28 DAYS
4. LIFTING HOOKS ARE 3/4" DIAMETER, ASTM A36 COLD ROLLED STEEL
5. SEPTIC TANK LID IS REINFORCED WITH 6 X 6 W8.0 X W8.0 WELDED WIRE FABRIC.
6. SEPTIC TANK BOTTOM AND SIDES ARE REINFORCED WITH 6 X 6 W10.0 X W10.0 WELDED WIRE FABRIC.
7. ALL CONCRETE SURFACES ABOVE THE LIQUID LEVEL ARE COATED WITH AIRLESS ASPHALT.

CASTING WEIGHTS

WEIGHT OF LID: 3,480.5 LBS
 WEIGHT OF TANK: 6,912.2 LBS
 TOTAL CASTING WEIGHT: 10,392.7 LBS

SEPTIC TANK CAPACITY:

28.2 GALLONS PER INCH
 STORAGE CAPACITY = 1297 GALLONS
 TOTAL VOLUME = 1628 GALLONS

NOTE:
 1. EXTENSIONS ARE AVAILABLE FOR 24" DIAMETER POLY RISERS
 2. 24" DIAMETER CONCRETE GRADE RINGS OR CUSTOM RECTANGULAR RISERS WITH ALUMINUM HATCHES ARE AVAILABLE AS SUBSTITUTES TO POLY RISER AS SHOWN HEREON.
 3. HIGH PRESSURE CLOSED END BOOT SEALS ARE AVAILABLE AS SUBSTITUTES TO RUBBER GASKET TYPE SEALS AS SHOWN HEREON.

KEYNOTE INDEX

1A	24" DIAMETER MANWAY
1B	20" DIAMETER MANHOLE OPENING
2	HIGH PRESSURE CLOSED END BOOT SEAL
3	MASTIC ROPE
4	SANITARY TEE AT INLET & OUTLET
5	3/4" DIAMETER LIFTING HOOKS
6	4" DIAMETER INLET (6" AVAILABLE UPON REQUEST)
7	4" DIAMETER OUTLET (6" AVAILABLE UPON REQUEST)
8	12" EXTENSION AT INLET
9	24" EXTENSION AT OUTLET
10	FLEXIBLE, NON-CORROSIVE POLYPROPYLENE GAS BAFFLE BY TUF-TITE AFFIXED WITH STAINLESS STEEL SCREWS
11	24" DIAMETER POLY RISER (18" HEIGHT TYP)
12	24" DIAMETER GAS TIGHT POLY SNAP CAP LID AFFIXED WITH STAINLESS STEEL SCREWS

RENSELAER SEPTIC TANKS

1211 NORTH WESTON STREET
 P.O. BOX 70
 RENSELAER, INDIANA 47978
 phone: (219) 866-5063
 (800) 240-5123
 fax: (219) 866-3894

PROJECT NAME _____
 CLIENT NAME _____
 ADDRESS _____

PROJECT NO: _____
 FILE: 1250 GAL- SINGLE- NT.DWG
 DRAWN BY: ASJM
 CHECKED BY: PEW

TITLE:
**MANUFACTURER'S
 DETAIL DRAWING**
 1250 GALLON SEPTIC TANK
 NO TRAFFIC

R-000

* ALL RENSELAER SEPTIC TANKS ARE MONOLITHICALLY POURED *

This drawing is the property of Rensselaer Septic Tanks. It is submitted for reference purposes only. © 2008 Rensselaer Septic Tanks