

6

5

4

3

2

1

E

D

C

B

A

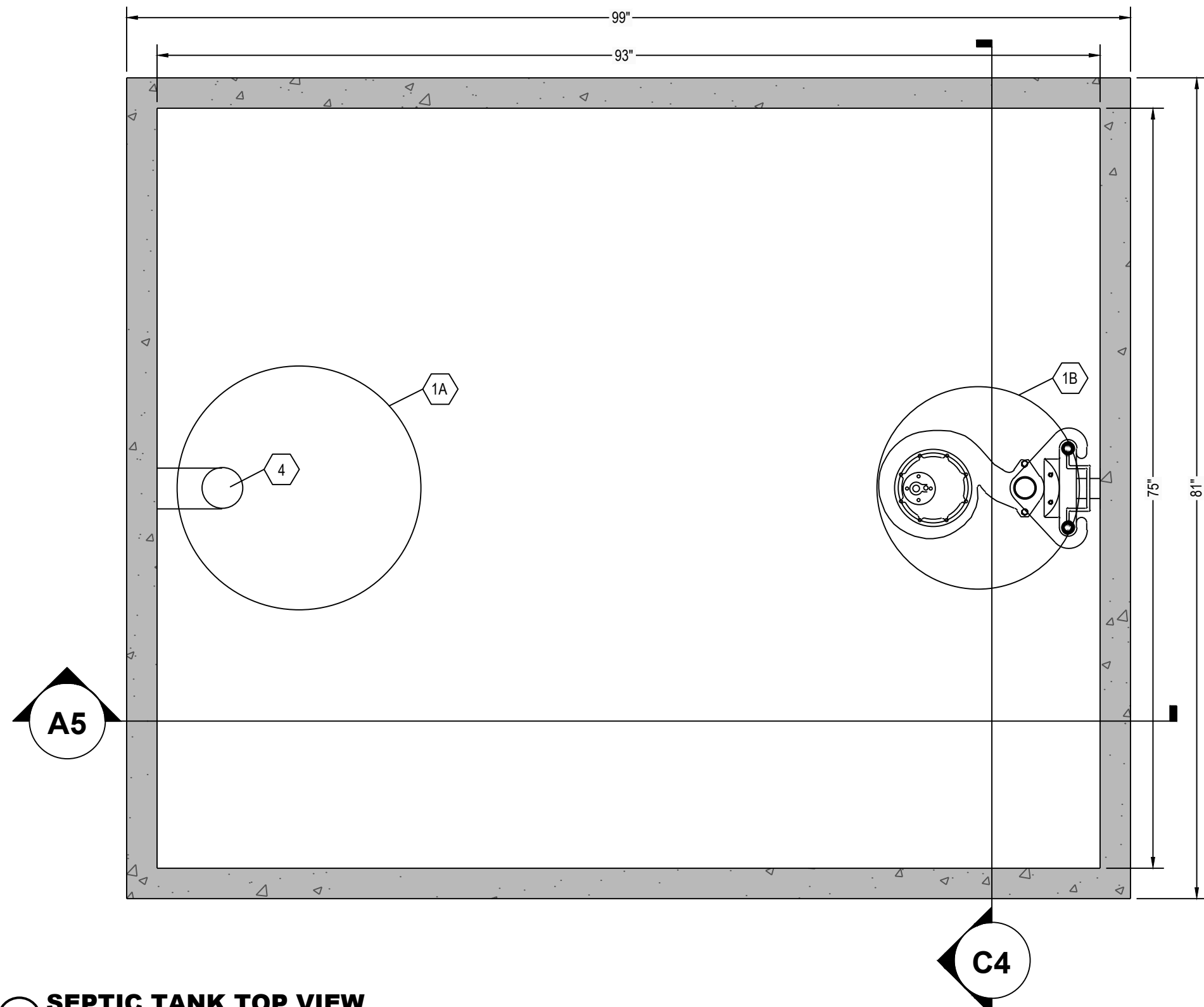

**C6 SEPTIC TANK TOP VIEW**  
1" = 1"

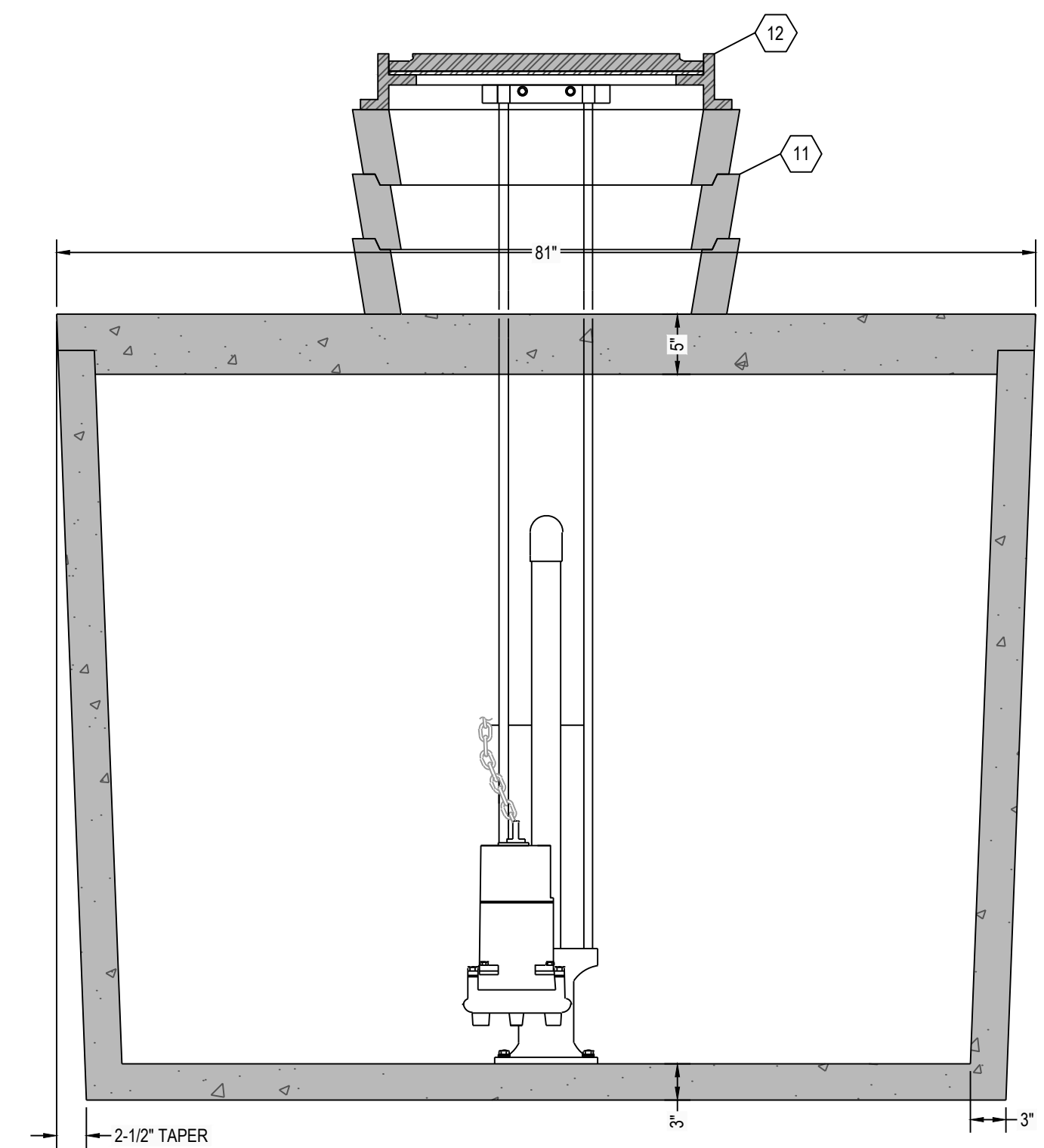

**C4 SEPTIC TANK SECTION VIEW**  
1" = 1"

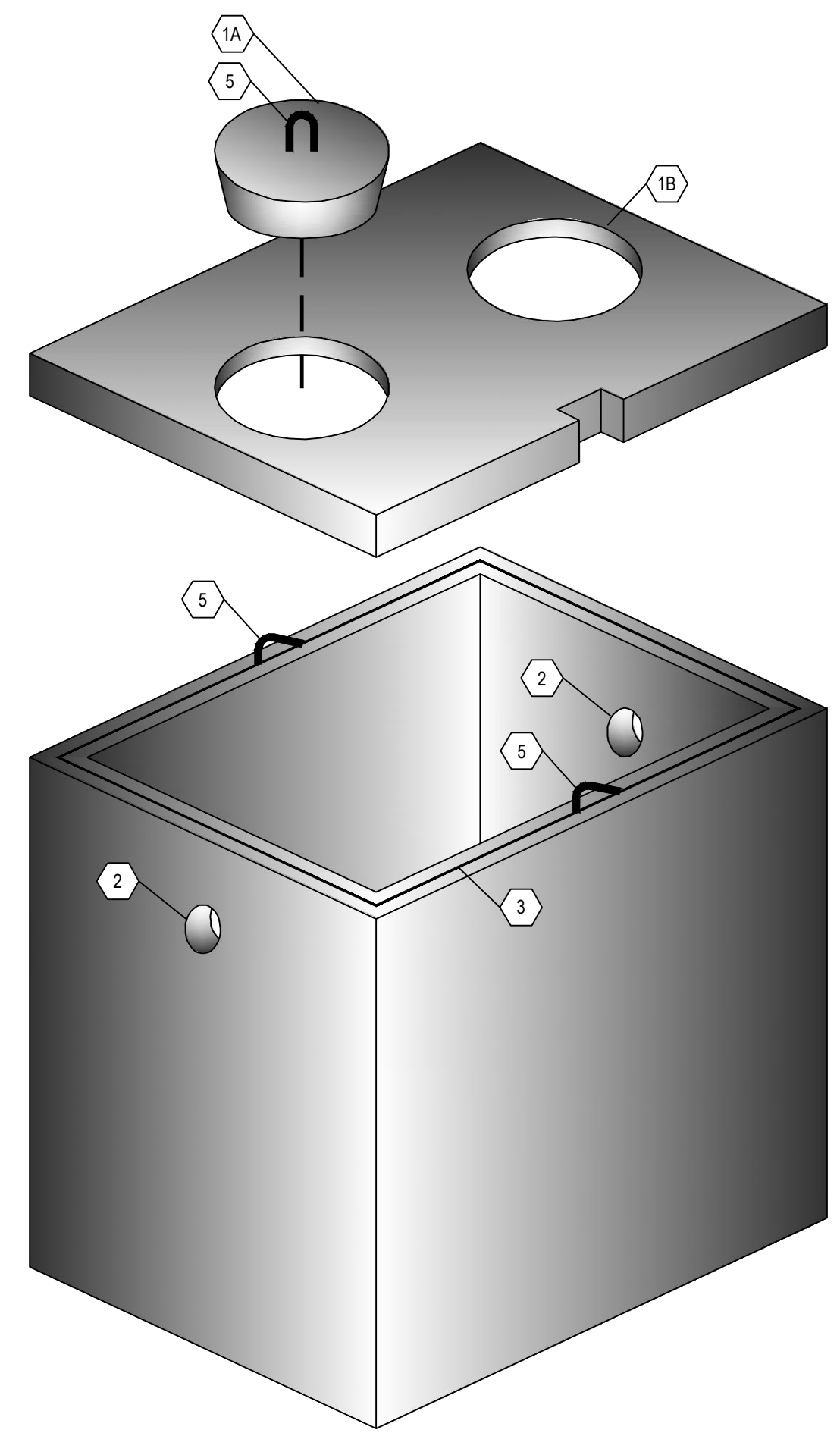

**A6 THREE DIMENSIONAL ISOMETRIC VIEW**  
NTS

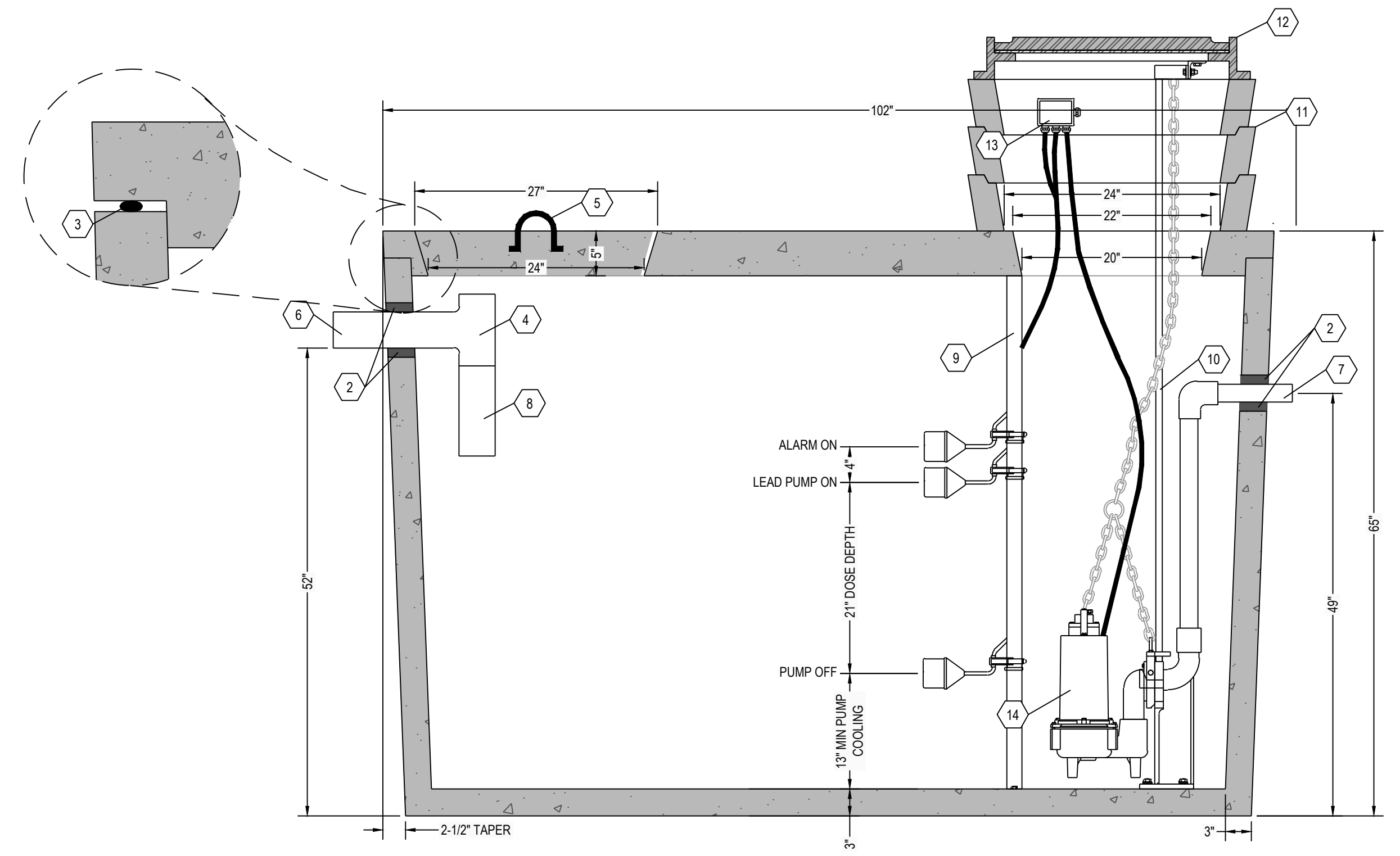

**A5 SEPTIC TANK SECTION VIEW**  
1" = 1"

**DESIGN DATA:**

- EARTH COVER = 3 FEET MAX
- ALLOWABLE WHEEL LOAD = 2500 LB MAX
- CONCRETE MINIMUM COMPRESSIVE STRENGTH = 5,000 PSI @ 28 DAYS
- LIFTING HOOKS ARE 3" DIAMETER, ASTM A36 COLD ROLLED STEEL
- SEPTIC TANK LID IS REINFORCED WITH 6 X 6 W8.0 X W8.0 WELDED WIRE FABRIC.
- SEPTIC TANK BOTTOM AND SIDES ARE REINFORCED WITH 6 X 6 W10.0 X W10.0 WELDED WIRE FABRIC.
- ALL CONCRETE SURFACES ARE COATED WITH AIRLESS ASPHALT.

**CASTING WEIGHTS**

WEIGHT OF LID: 3,480.5 LBS  
 WEIGHT OF TANK: 6,912.2 LBS  
 TOTAL CASTING WEIGHT: 10,392.7 LBS

**DOSING TANK CAPACITY:**

LIQUID STORAGE = 1297 GALLONS  
 TOTAL VOLUME = 1628 GALLONS

28.2 GALLONS PER INCH  
 MAXIMUM DOSE = XXX GALLONS (XX)  
 PUMP COOLING = 367 GALLONS (13")  
 UNUSED (ALARM) = 113 GALLONS (4")  
 TOTAL = XXX GALLONS (XX)

**NOTES:**

- SET PUMP ON FLOAT SWITCH ELEVATION ACCORDING TO ELEVATION TABLE (BELOW), WHICH YIELDS THE REQUIRED DOSE VOLUME OF XXX GALLONS.
- CONTRACTOR SHALL INSTALL CONTROL PANEL ACCORDING TO PUMP MANUFACTURER'S RECOMMENDATION.
- COORDINATE POWER & ALARM SERVICE PRIOR TO CONSTRUCTION ACTIVITIES
- ONLY NON-CORROSIVE MATERIALS SHALL BE UTILIZED WITHIN THE DOSING TANK AND FOR THE RISER AND LID (NO GALVANIZED, PAINTED, OR EXPOSED STEEL).
- AUDIO VISUAL ALARM CIRCUIT MUST LOCK ON WITH ANY PUMP FAILURE WITH MANUAL RESET.

**NOTE:**  
 1. 24" DIAMETER POLY RISERS OR CUSTOM RECTANGULAR RISERS WITH ALUMINUM HATCHES ARE AVAILABLE AS SUBSTITUTES TO POLY RISER AS SHOWN HEREON.  
 3. HIGH PRESSURE CLOSED END BOOT SEALS ARE AVAILABLE AS SUBSTITUTES TO RUBBER GASKET TYPE SEALS AS SHOWN HEREON.

DOSING CHAMBER ELEVATIONS	
DESCRIPTION	ELEVATION (FEET)
BOTTOM OF CHAMBER	0.00
PUMP OFF	1.08
PUMP ON	2.83
ALARM	3.17
LAG PUMP ON	N/A

KEYNOTE INDEX	
1A	24" DIAMETER MANWAY
1B	20" DIAMETER MANHOLE OPENING
2	HIGH PRESSURE CLOSED END BOOT SEAL
3	MASTIC ROPE
4	SANITARY TEE AT INLET
5	3/4" DIAMETER LIFTING HOOKS
6	4" DIAMETER INLET (6" AVAILABLE UPON REQUEST)
7	X" DIAMETER OUTLET
8	12" EXTENSION AT INLET
9	FLOAT POLE ASSEMBLY WITH STAINLESS STEEL HARDWARE
10	RAIL SYSTEM WITH STAINLESS STEEL RAILS & HARDWARE
11	CONCRETE GRADE RING (AS NECESSARY)
12	CAST FRAME & COVER (NOT INCLUDED)
13	WATERTIGHT ELECTRICAL JUNCTION BOX
14	DOSING PUMP

# RENSELAER SEPTIC TANKS

1211 NORTH WESTON STREET  
 P.O. BOX 70  
 RENSELAER, INDIANA 47978  
 phone: (219) 866-5063  
 (800) 240-5123  
 fax: (219) 866-3894

PROJECT NAME  
 CLIENT NAME  
 ADDRESS

PROJECT NO: ---  
 FILE: 1250 GAL - SINGLE HT - SIMPLEX CONCRETE RISER.DWG  
 DRAWN BY: ASJM  
 CHECKED BY: PEW  
 TITLE:  
**MANUFACTURER'S  
 DETAIL DRAWING**  
 1250 GALLON SIMPLEX CHAMBER  
 NO TRAFFIC

**R-000**

\* ALL RENSELAER SEPTIC TANKS ARE MONOLITHICALLY Poured \*

This drawing is the property of Rensselaer Septic Tanks. It is submitted for reference purposes only. © 2008 Rensselaer Septic Tanks