

6

5

4

3

2

1

E

D

C

B

A

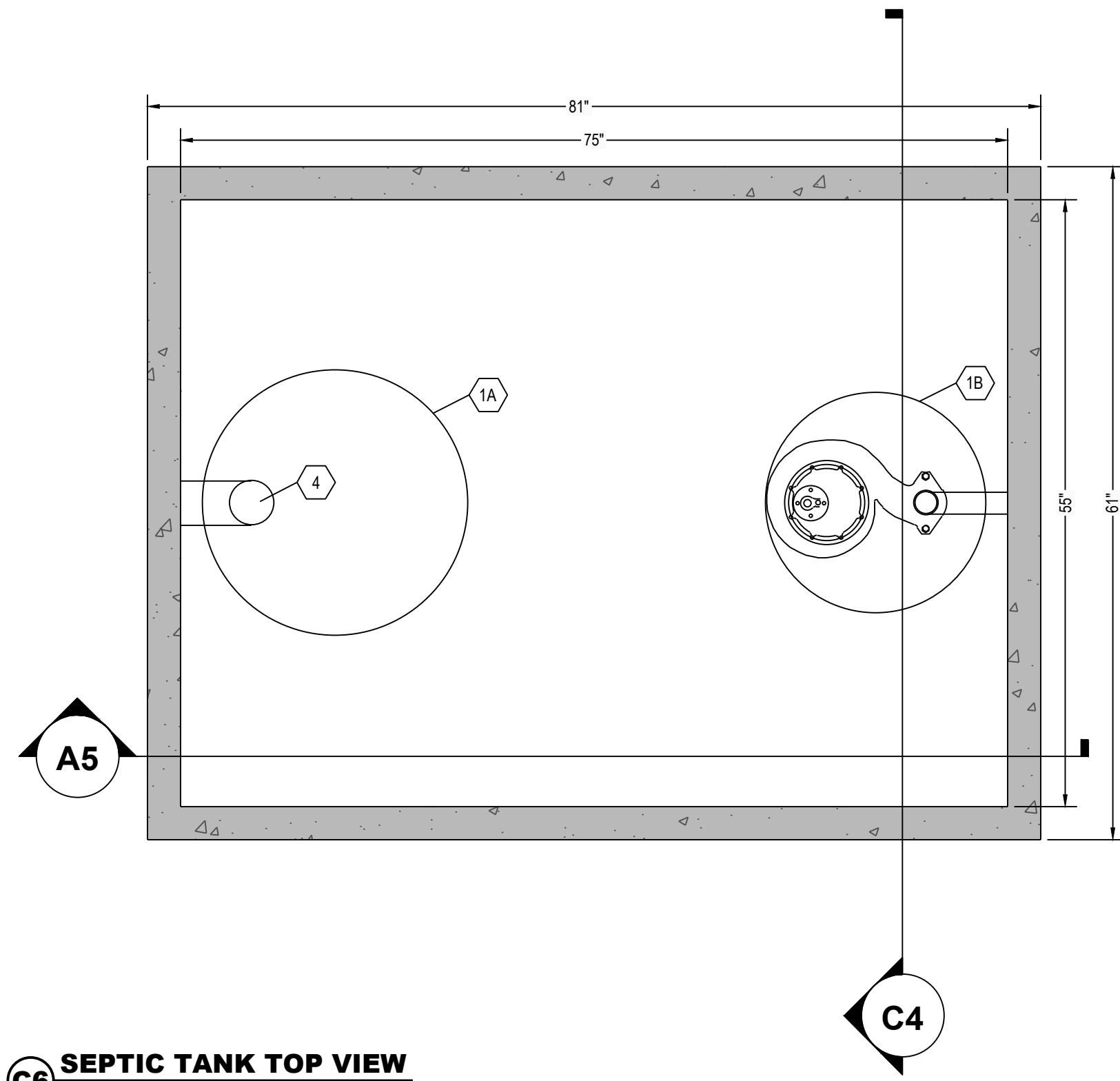

C6 SEPTIC TANK TOP VIEW
1"=1"

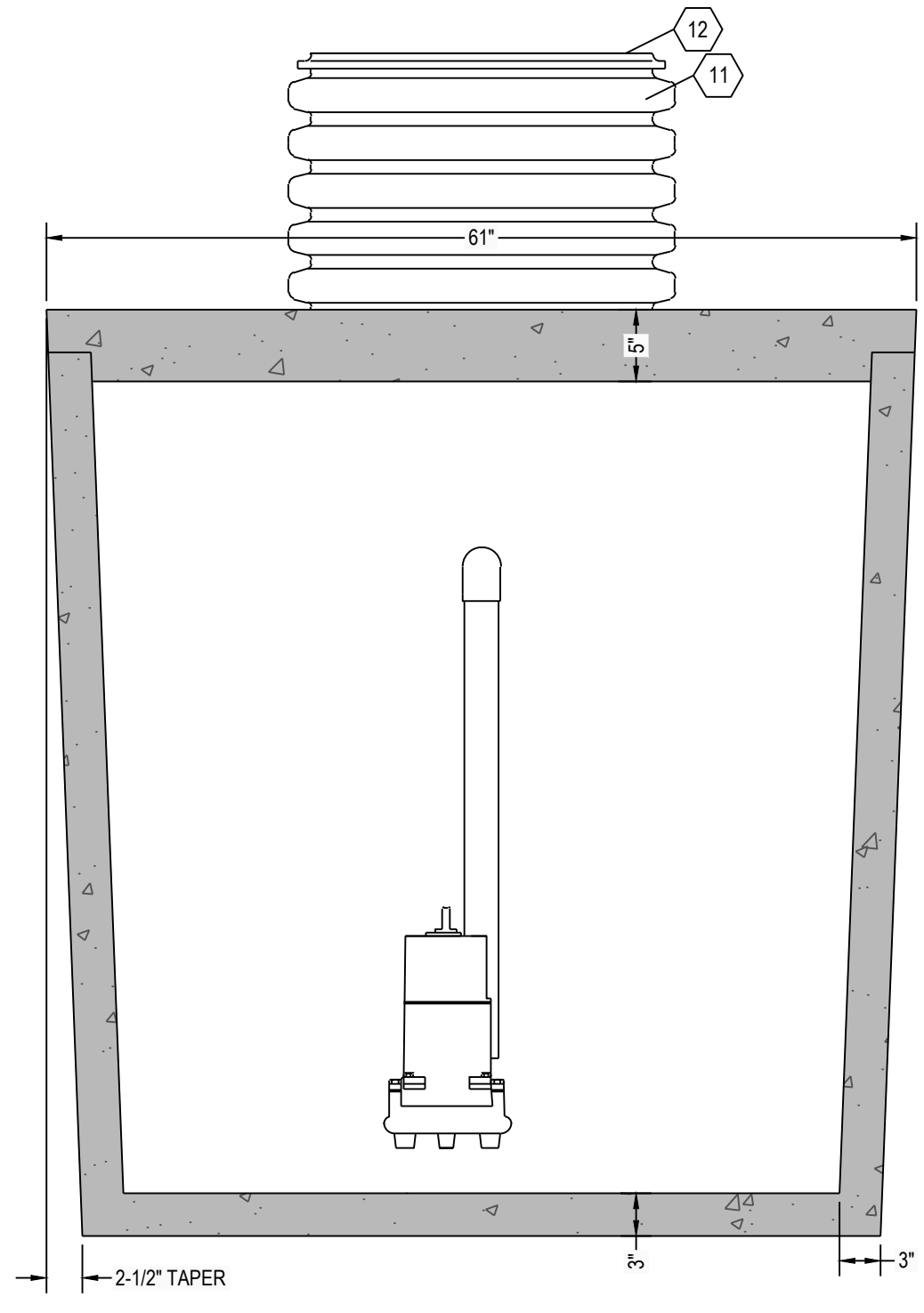

C4 SEPTIC TANK SECTION VIEW
1"=1"

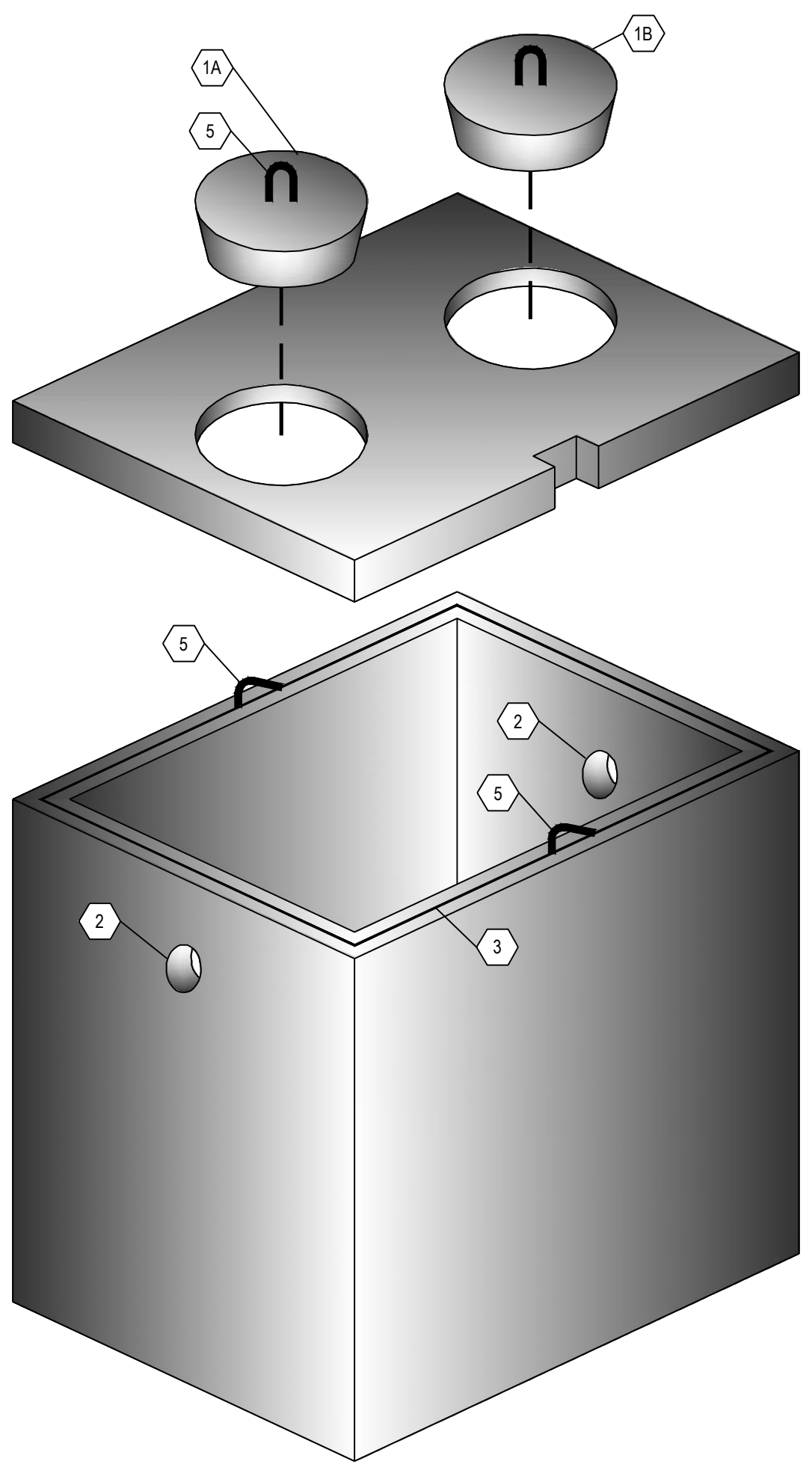

A6 THREE DIMENSIONAL ISOMETRIC VIEW
NTS

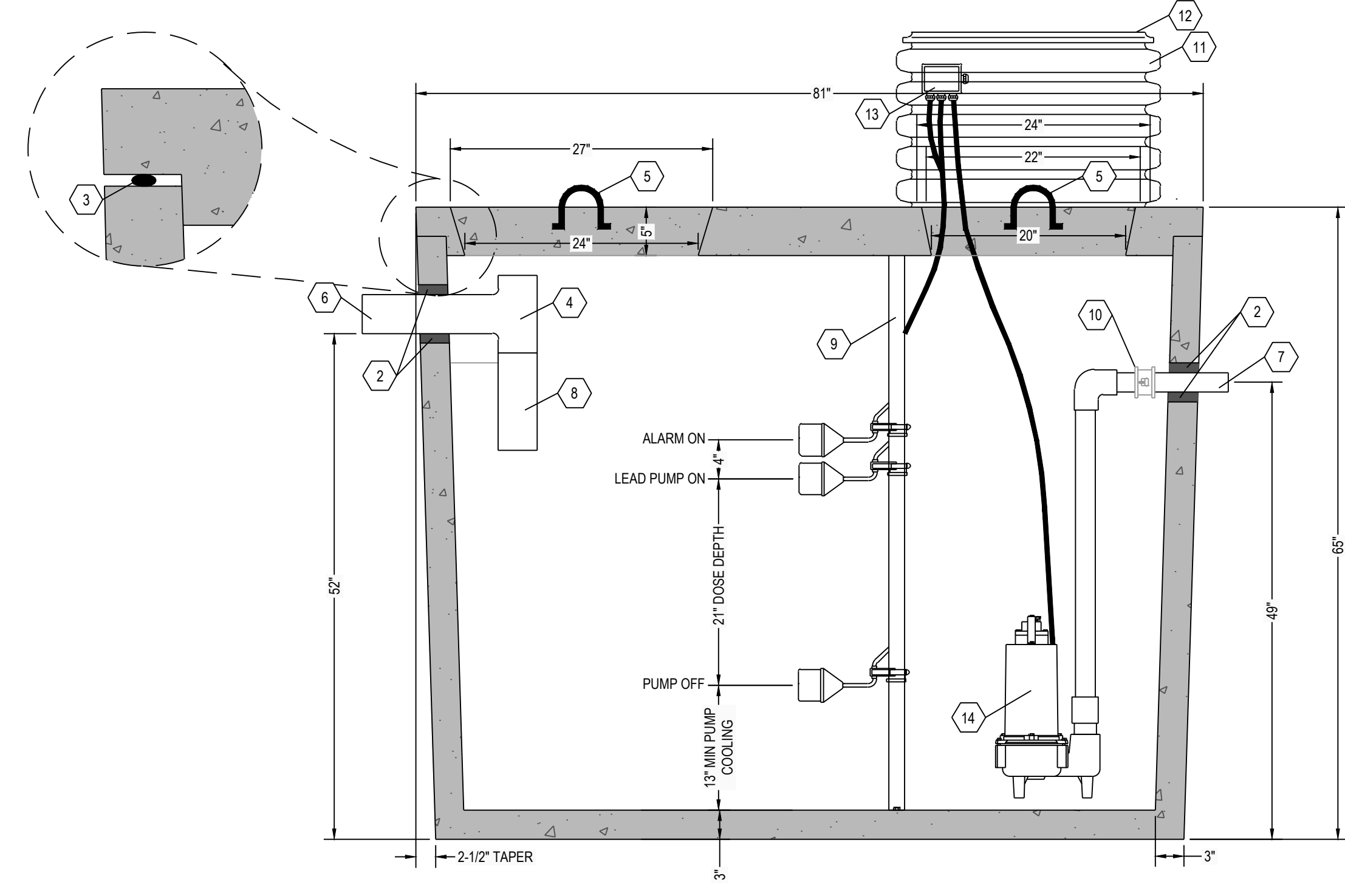

A5 SEPTIC TANK SECTION VIEW
1"=1"

NOTE:

- EXTENSIONS ARE AVAILABLE FOR 24" DIAMETER POLY RISERS
- 24" DIAMETER CONCRETE GRADE RINGS OR CUSTOM RECTANGULAR RISERS WITH ALUMINUM HATCHES ARE AVAILABLE AS SUBSTITUTES TO POLY RISER AS SHOWN HEREON.
- HIGH PRESSURE CLOSED END BOOT SEALS ARE AVAILABLE AS SUBSTITUTES TO RUBBER GASKET TYPE SEALS AS SHOWN HEREON.

DESCRIPTION	ELEVATION (FEET)
BOTTOM OF CHAMBER	0.00
PUMP OFF	1.08
PUMP ON	2.83
ALARM	3.17
LAG PUMP ON	N/A

1A	24" DIAMETER MANWAY
1B	20" DIAMETER MANHOLE OPENING
2	HIGH PRESSURE CLOSED END BOOT SEAL
3	MASTIC ROPE
4	SANITARY TEE AT INLET
5	3/4" DIAMETER LIFTING HOOKS
6	4" DIAMETER INLET (6" AVAILABLE UPON REQUEST)
7	1" DIAMETER OUTLET
8	12" EXTENSION AT INLET
9	FLOAT POLE ASSEMBLY WITH STAINLESS STEEL HARDWARE
10	1" DIAMETER BANJO® POLYPROPYLENE QUICK DISCONNECT
11	24" DIAMETER POLY RISER (18" HEIGHT TYP)
12	24" DIAMETER GAS TIGHT POLY SNAP CAP LID AFFIXED WITH STAINLESS STEEL SCREWS
13	WATERTIGHT ELECTRICAL JUNCTION BOX
14	DOSEING PUMP

DESIGN DATA:

- EARTH COVER = 3 FEET MAX
- ALLOWABLE WHEEL LOAD = 2500 LB MAX
- CONCRETE MINIMUM COMPRESSIVE STRENGTH = 5,050 PSI @ 28 DAYS
- LIFTING HOOKS ARE 3" DIAMETER, ASTM A36 COLD ROLLED STEEL
- SEPTIC TANK LID IS REINFORCED WITH 6 X 6 W8.0 X W8.0 WELDED WIRE FABRIC
- SEPTIC TANK BOTTOM AND SIDES ARE REINFORCED WITH 6 X 6 W10.0 X W10.0 WELDED WIRE FABRIC
- ALL CONCRETE SURFACES ARE COATED WITH AIRLESS ASPHALT.

CASTING WEIGHTS

WEIGHT OF LID: 2,144.5 LBS
 WEIGHT OF TANK: 5,210.2 LBS
 TOTAL CASTING WEIGHT: 7,354.7 LBS

DOSEING TANK CAPACITY:

LIQUID STORAGE = 753 GALLONS
 TOTAL VOLUME = 949 GALLONS

16.4 GALLONS PER INCH
 MAXIMUM DOSE = XXX GALLONS (XX)
 PUMP COOLING = 213 GALLONS (13")
 UNUSED (ALARM) = 66 GALLONS (4")
 TOTAL = XXX GALLONS (XX)

NOTES:

- SET PUMP ON FLOAT SWITCH ELEVATION ACCORDING TO ELEVATION TABLE (BELOW); WHICH YIELDS THE REQUIRED DOSE VOLUME OF XXX GALLONS.
- CONTRACTOR SHALL INSTALL CONTROL PANEL ACCORDING TO PUMP MANUFACTURER'S RECOMMENDATION.
- COORDINATE POWER & ALARM SERVICE PRIOR TO CONSTRUCTION ACTIVITIES
- ONLY NON-CORROSIVE MATERIALS SHALL BE UTILIZED WITHIN THE DOSEING TANK AND FOR THE RISER AND LID (NO GALVANIZED, PAINTED, OR EXPOSED STEEL).
- AUDIO VISUAL ALARM CIRCUIT MUST LOCK ON WITH ANY PUMP FAILURE WITH MANUAL RESET.

RENSELAER SEPTIC TANKS

1211 NORTH WESTON STREET
 P.O. BOX 70
 RENSELAER, INDIANA 47978
 phone: (219) 866-5063
 (800) 240-5123
 fax: (219) 866-3894

PROJECT NAME
 CLIENT NAME
 ADDRESS

PROJECT NO: _____
 FILE: 750 GAL-SINGLE-INT-SIMPLEX.DWG
 DRAWN BY: ASJM
 CHECKED BY: PEW
 TITLE:
**MANUFACTURER'S
 DETAIL DRAWING**
 750 GALLON SIMPLEX CHAMBER
 NO TRAFFIC

R-000

* ALL RENSELAER SEPTIC TANKS ARE MONOLITHICALLY POURED *

This drawing is the property of Rensselaer Septic Tanks. It is submitted for reference purposes only. © 2008 Rensselaer Septic Tanks