

6

5

4

3

2

1

E

D

C

B

A

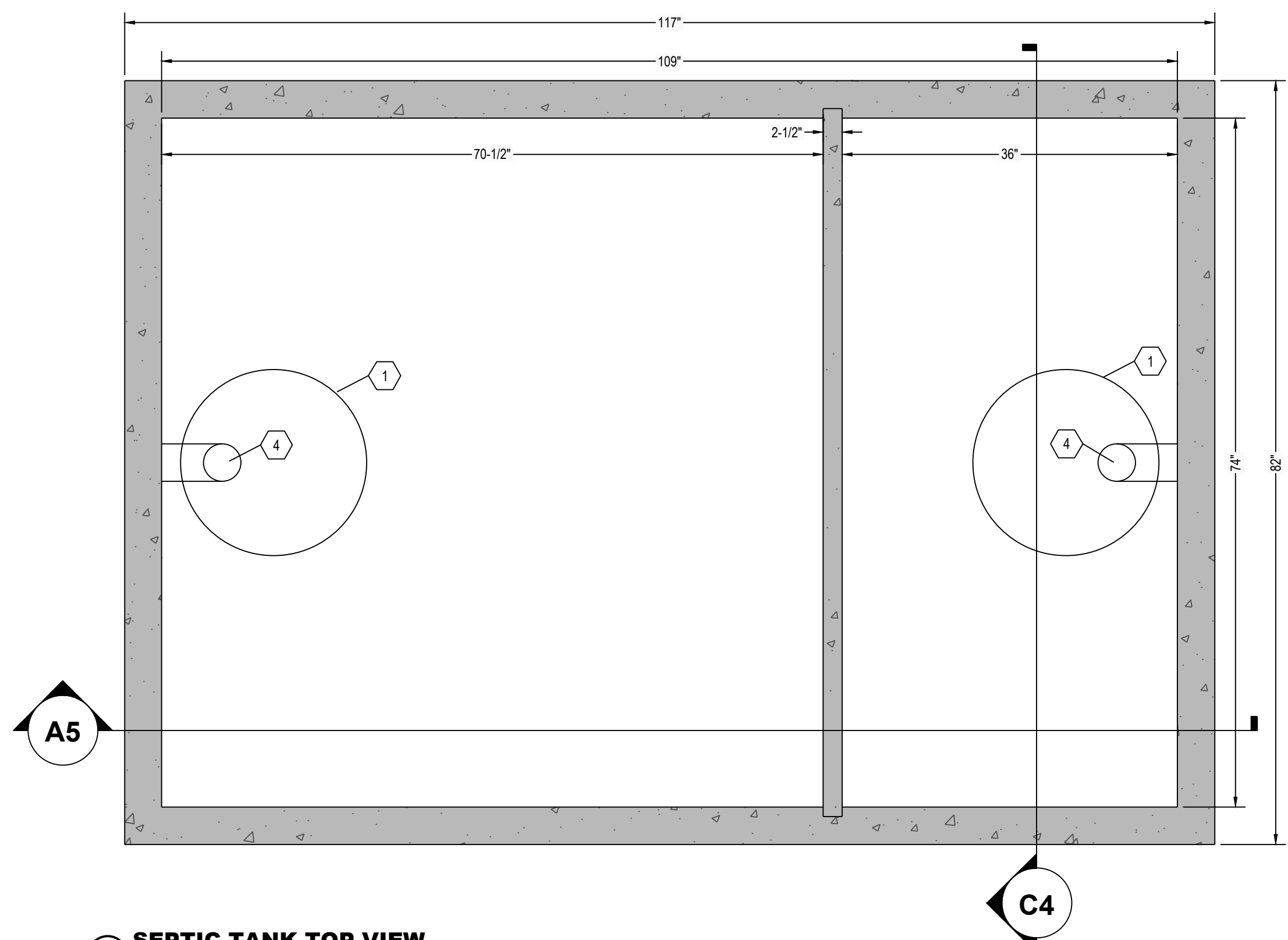

**C6 SEPTIC TANK TOP VIEW**  
1" = 1"

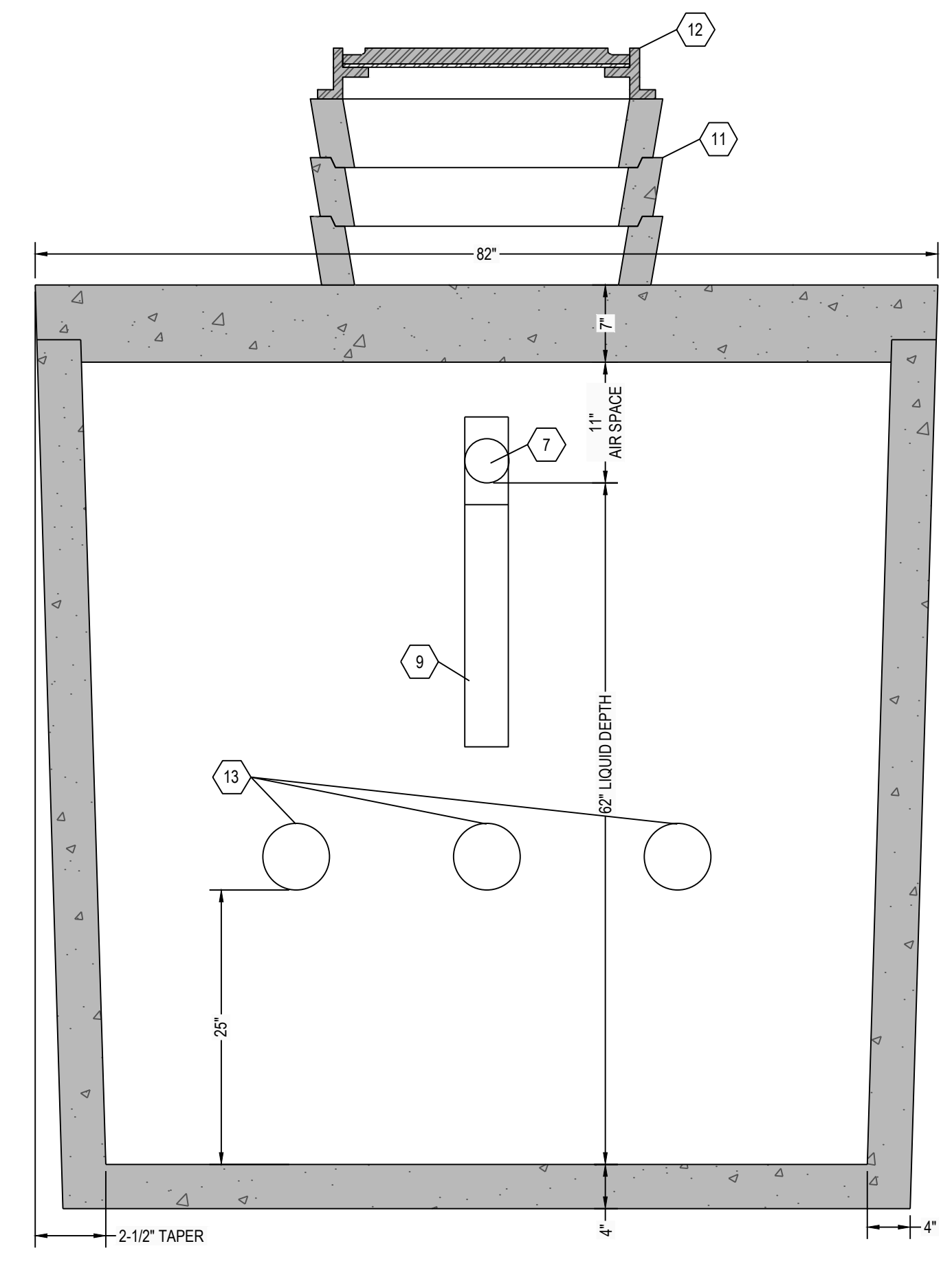

**C4 SEPTIC TANK SECTION VIEW**  
1" = 1"

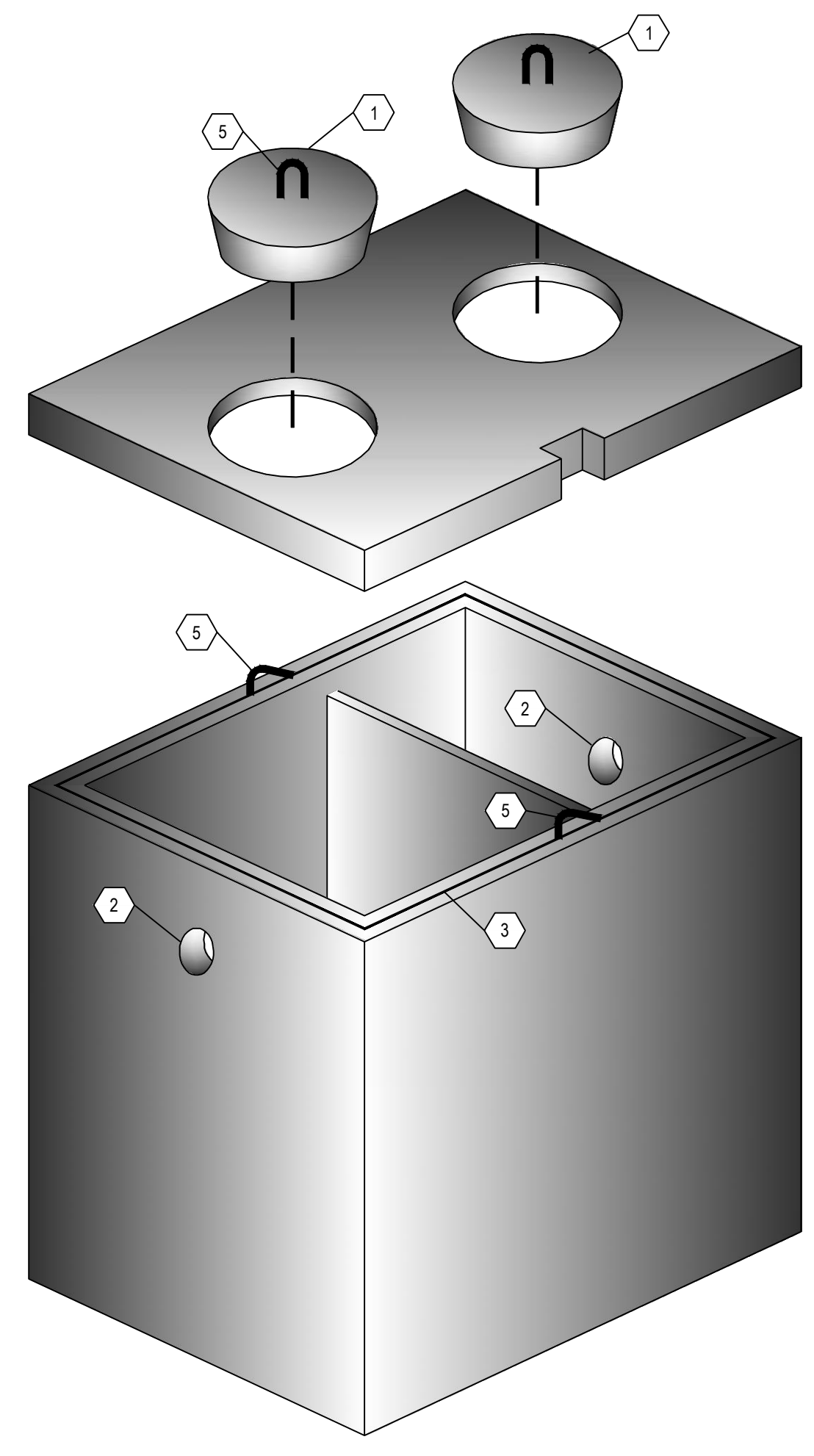

**A6 THREE DIMENSIONAL ISOMETRIC VIEW**  
NTS

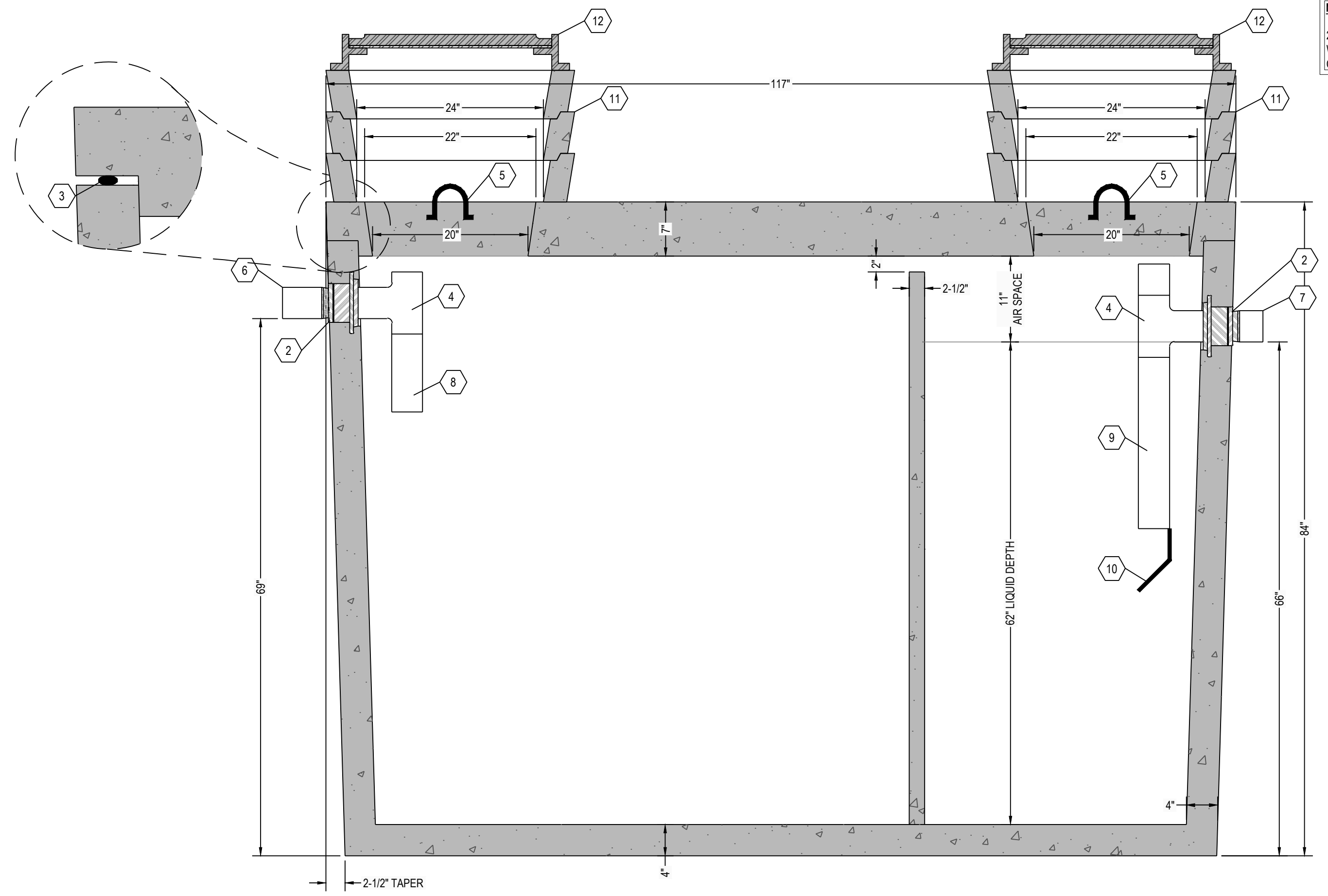

**A5 SEPTIC TANK SECTION VIEW**  
1" = 1"

**NOTE:**  
24" DIAMETER POLY RISERS & LIDS OR CUSTOM RECTANGULAR RISERS WITH ALUMINUM HATCHES ARE AVAILABLE AS SUBSTITUTES TO CONCRETE GRADE RINGS AS SHOWN HEREON.

**DESIGN DATA:**

1. EARTH COVER = 5 FEET MAX.
2. ALLOWABLE WHEEL LOAD = 8000 LB MAX.
3. CONCRETE MINIMUM COMPRESSIVE STRENGTH = 5,090 PSI @ 28 DAYS.
4. LIFTING HOOKS ARE 1" DIAMETER, ASTM A36 COLD ROLLED STEEL.
5. SEPTIC TANK LID IS REINFORCED WITH #3 REBAR SPACED AT 12" OC GRID.
6. SEPTIC TANK BOTTOM AND SIDES ARE REINFORCED WITH 6 X 6 W8.0 X W8.0 WELDED WIRE FABRIC.
7. ALL CONCRETE SURFACES ABOVE THE LIQUID LEVEL ARE COATED WITH AIRLESS ASPHALT.

**CASTING WEIGHTS:**

WEIGHT OF LID: 5.697 LBS  
 WEIGHT OF TANK: 12.494 LBS  
 TOTAL CASTING WEIGHT: 18.191 LBS

**(2) COMPARTMENT TANK CAPACITY:**

FIRST COMPARTMENT CAPACITY = 1317 GALLONS  
 21.2 GALLONS PER INCH  
 SECOND COMPARTMENT CAPACITY = 683 GALLONS  
 11.0 GALLONS PER INCH

STORAGE CAPACITY = 2000 GALLONS  
 TOTAL VOLUME = 2584 GALLONS

**KEYNOTE INDEX**

1	20" DIAMETER MANHOLE OPENING
2	HIGH PRESSURE CLOSED END BOOT SEAL
3	MASTIC ROPE
4	SANITARY TEE AT INLET & OUTLET
5	5/8" DIAMETER LIFTING HOOKS
6	6" DIAMETER INLET
7	6" DIAMETER OUTLET
8	12" EXTENSION AT INLET
9	24" EXTENSION AT OUTLET
10	FLEXIBLE, NON-CORROSIVE POLYPROPYLENE GAS BAFFLE BY TUF-TITE AFFIXED WITH STAINLESS STEEL SCREWS
11	CONCRETE GRADE RING (AS NECESSARY)
12	CAST FRAME & COVER (NOT INCLUDED)
13	THREE (3) 6" DIAMETER HOLES THROUGH INTERIOR WALL

# RENSELAER SEPTIC TANKS

1211 NORTH WESTON STREET  
 P.O. BOX 70  
 RENSELAER, INDIANA 47978  
 phone: (219) 866-5063  
 (800) 240-5123  
 fax: (219) 866-3894

PROJECT NAME  
 CLIENT NAME  
 ADDRESS

PROJECT NO:  
 FILE: 2000 GAL- DUAL- TR.DWG  
 DRAWN BY: ASJM  
 CHECKED BY: PEW

TITLE:  
**MANUFACTURER'S  
 DETAIL DRAWING**  
 2000 GALLON (2) COMPARTMENT  
 TRAFFIC RATED

**R-000**

*\* ALL RENSELAER SEPTIC TANKS ARE MONOLITHICALLY POURED \**

This drawing is the property of Rensselaer Septic Tanks. It is submitted for reference purposes only. © 2008 Rensselaer Septic Tanks.