

6

5

4

3

2

1

E

D

C

B

A



C5 SEPTIC TANK TOP VIEW
1" = 1"

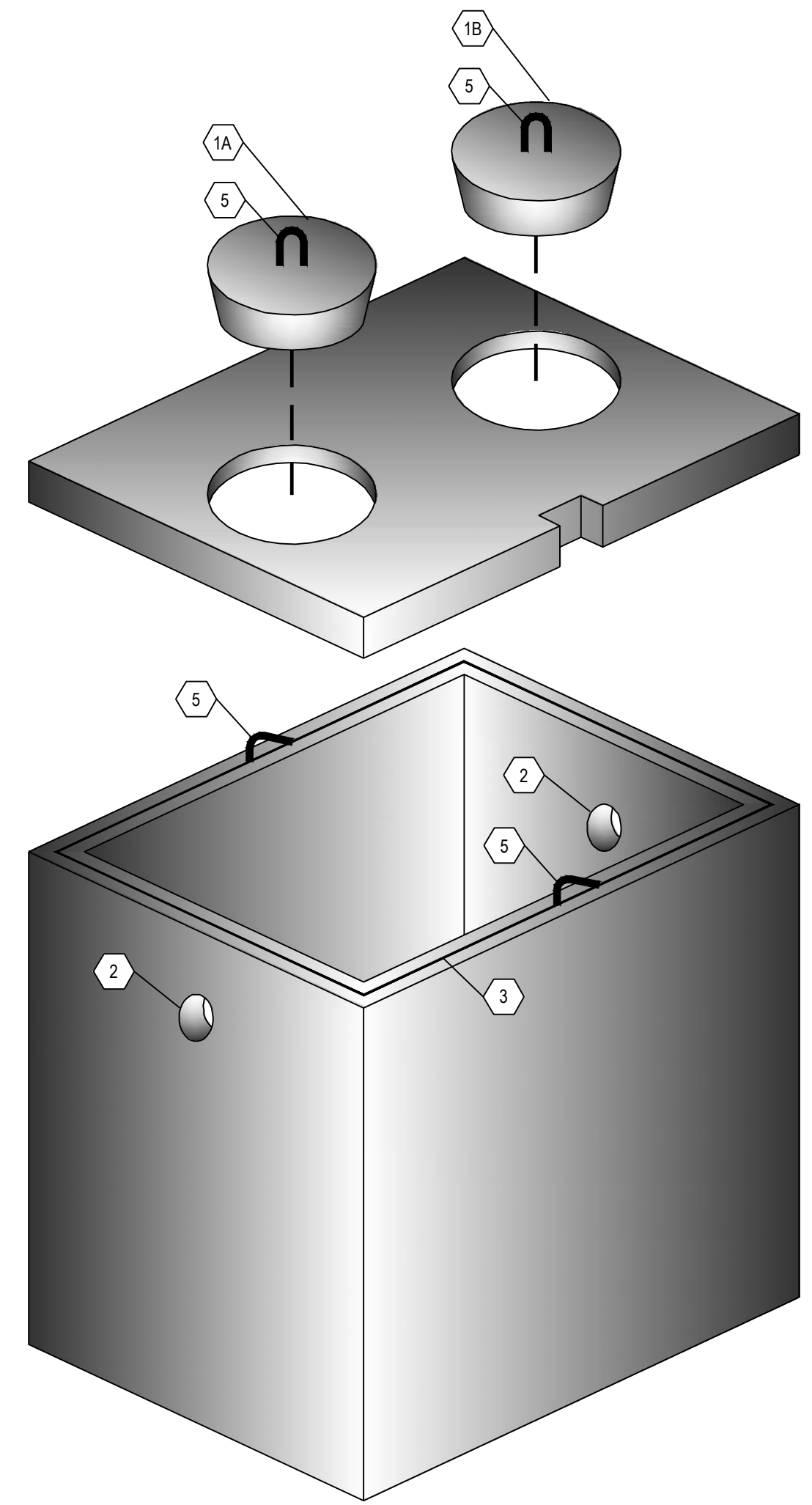

A6 THREE DIMENSIONAL ISOMETRIC VIEW
NTS

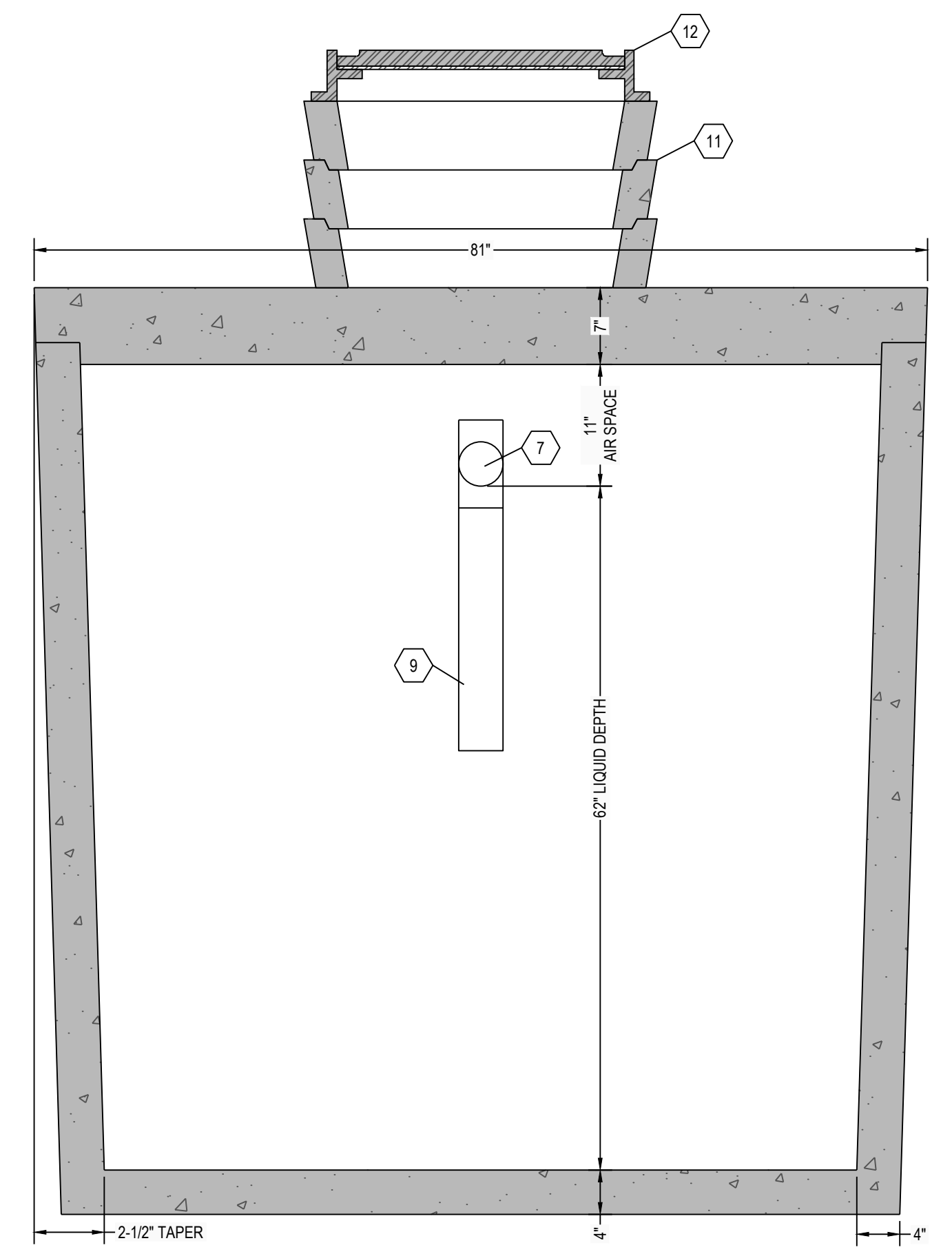

C3 SEPTIC TANK SECTION VIEW
1" = 1"

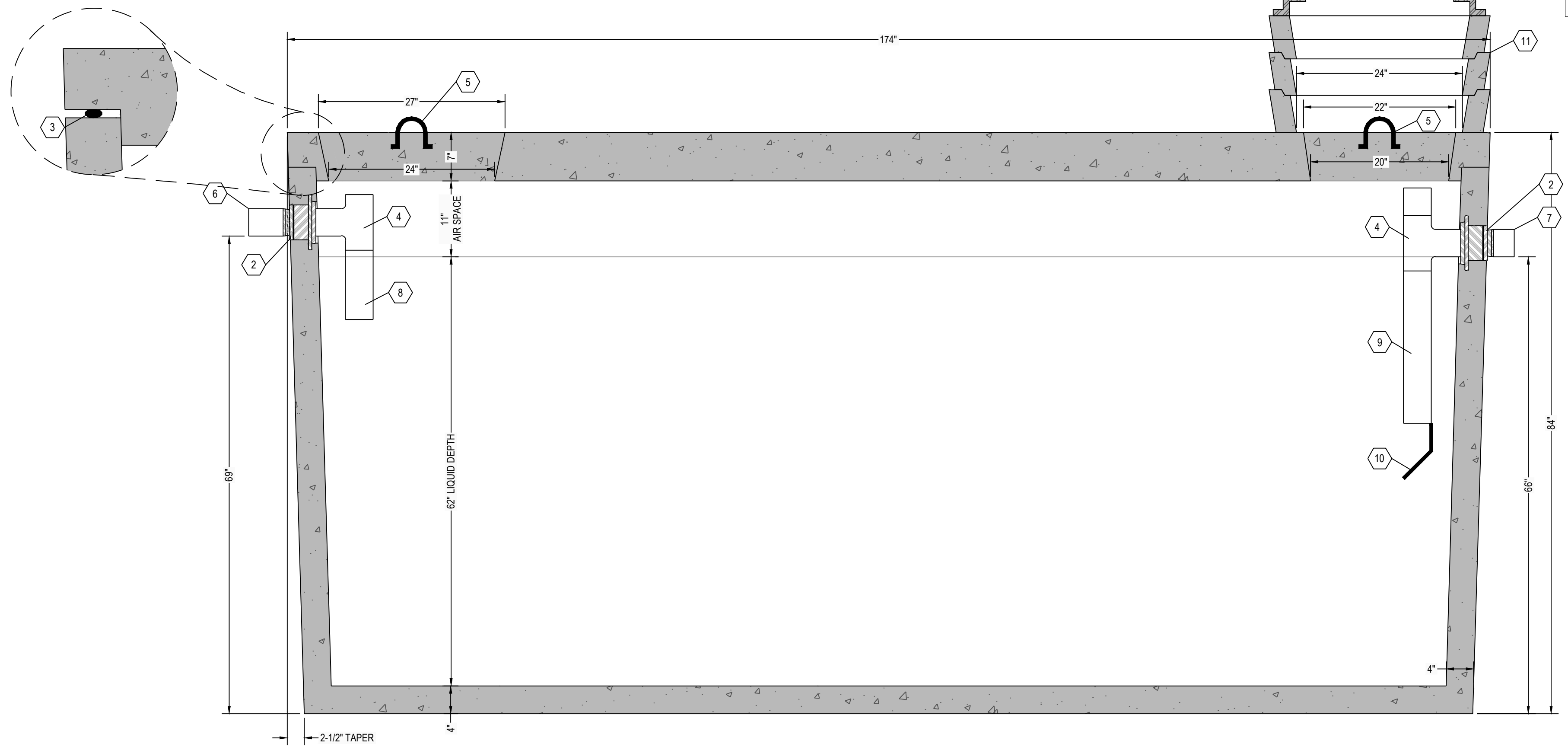

A5 SEPTIC TANK SECTION VIEW
1" = 1"

- DESIGN DATA:**
1. EARTH COVER = 5 FEET MAX
 2. ALLOWABLE WHEEL LOAD = 8000 LB MAX
 3. CONCRETE MINIMUM COMPRESSIVE STRENGTH = 5,000 PSI @ 28 DAYS
 4. LIFTING HOOKS ARE 1/2" DIAMETER, ASTM A36 COLD ROLLED STEEL
 5. SEPTIC TANK LID IS REINFORCED WITH #3 REBAR SPACED AT 12" OC GRID.
 6. SEPTIC TANK BOTTOM AND SIDES ARE REINFORCED WITH 6 X 6 W8.0 X W8.0 WELDED WIRE FABRIC.
 7. ALL CONCRETE SURFACES ABOVE THE LIQUID LEVEL ARE COATED WITH AIRLESS ASPHALT.

CASTING WEIGHTS

WEIGHT OF LID: 8,497.6 LBS
 WEIGHT OF TANK: 17,222.8 LBS
 TOTAL CASTING WEIGHT: 25,720.4 LBS

SEPTIC TANK CAPACITY:

50.2 GALLONS PER INCH
 STORAGE CAPACITY = 3,112 GALLONS
 TOTAL VOLUME = 3,695 GALLONS

NOTE:
 24" DIAMETER POLY RISERS & LIDS OR CUSTOM RECTANGULAR RISERS WITH ALUMINUM HATCHES ARE AVAILABLE AS SUBSTITUTES TO CONCRETE GRADE RINGS AS SHOWN HEREON.

KEYNOTE INDEX	
1A	24" DIAMETER MANWAY
1B	20" DIAMETER MANHOLE OPENING
2	HIGH PRESSURE CLOSED END BOOT SEAL
3	MASTIC ROPE
4	SANITARY TEE AT INLET & OUTLET
5	1/2" DIAMETER LIFTING HOOKS
6	6" DIAMETER INLET
7	6" DIAMETER OUTLET
8	12" EXTENSION AT INLET
9	24" EXTENSION AT OUTLET
10	FLEXIBLE, NON-CORROSIVE POLYPROPYLENE GAS BAFFLE BY TUF-TITE AFFIXED WITH STAINLESS STEEL SCREWS
11	CONCRETE GRADE RING (AS NECESSARY)
12	CAST FRAME & COVER (NOT INCLUDED)

RENSELAER SEPTIC TANKS

1211 NORTH WESTON STREET
 P.O. BOX 70
 RENSELAER, INDIANA 47978
 phone: (219) 866-5063
 (800) 240-5123
 fax: (219) 866-3894

PROJECT NAME
 CLIENT NAME
 ADDRESS

PROJECT NO:
 FILE: 3000 GAL- SINGLE- TR.DWG
 DRAWN BY: ASJM
 CHECKED BY: PEW

TITLE:
**MANUFACTURER'S
 DETAIL DRAWING**
 3000 GALLON SEPTIC TANK
 TRAFFIC RATED

R-000

* ALL RENSELAER SEPTIC TANKS ARE MONOLITHICALLY Poured *

This drawing is the property of Rensselaer Septic Tanks. It is submitted for reference purposes only. © 2008 Rensselaer Septic Tanks.