

6

5

4

3

2

1

DESIGN DATA:

- EARTH COVER = 5 FEET MAX
- ALLOWABLE WHEEL LOAD = 8000 LB MAX
- CONCRETE MINIMUM COMPRESSIVE STRENGTH = 5,000 PSI @ 28 DAYS
- LIFTING HOOKS ARE 1" DIAMETER, ASTM A36 COLD ROLLED STEEL
- SEPTIC TANK LID IS REINFORCED WITH #3 REBAR SPACED AT 12" OC GRID
- SEPTIC TANK BOTTOM AND SIDES ARE REINFORCED WITH 6 X 6 W8.0 X W8.0 WELDED WIRE FABRIC.
- ALL CONCRETE SURFACES ABOVE THE LIQUID LEVEL ARE COATED WITH AIRLESS ASPHALT.

CASTING WEIGHTS

WEIGHT OF LID: 8,497.6 LBS
 WEIGHT OF TANK: 17,222.8 LBS
 TOTAL CASTING WEIGHT: 25,720.4 LBS

SEPTIC COMPARTMENT CAPACITY:
 LIQUID STORAGE = 2026 GALLONS
 32.7 GALLONS PER INCH

DOSING COMPARTMENT CAPACITY:
 LIQUID STORAGE = 1006 GALLONS
 16.2 GALLONS PER INCH
 MAXIMUM DOSE = XXX GALLONS (XX)
 PUMP COOLING = 211 GALLONS (13")
 UNUSED (ALARM) = 65 GALLONS (4")
 TOTAL = XXX GALLONS (XX")

NOTES:

- SET PUMP ON FLOAT SWITCH ELEVATION ACCORDING TO ELEVATION TABLE (BELOW), WHICH YIELDS THE REQUIRED DOSE VOLUME OF XXX GALLONS.
- CONTRACTOR SHALL INSTALL CONTROL PANEL ACCORDING TO PUMP MANUFACTURER'S RECOMMENDATION.
- COORDINATE POWER & ALARM SERVICE PRIOR TO CONSTRUCTION ACTIVITIES
- ONLY NON-CORROSIVE MATERIALS SHALL BE UTILIZED WITHIN THE DOSING TANK AND FOR THE RISER AND LID (NO GALVANIZED, PAINTED, OR EXPOSED STEEL).
- AUDIO VISUAL ALARM CIRCUIT MUST LOCK ON WITH ANY PUMP FAILURE WITH MANUAL RESET.
- THE INLET PORTS THROUGH THE INTERIOR WALL SHALL BE PROVIDED WITH A SANITARY TEE AND TS-4PRO RUBBER GASKET SEAL BY TUF-TITE. THE SANITARY TEE SHALL BE LOCATED OUTSIDE THE PUMP VAULT (IN THE SEPTIC COMPARTMENT). A 12" LONG DOWNWARD EXTENSION SHALL BE PROVIDED AT THE SANITARY TEE. AN UPWARD EXTENSION SHALL BE PROVIDED AT THE SANITARY TEE SUCH THAT THE TOP OF EXTENSION EXTENDS BEYOND THE ALARM ELEVATION.

DOSING CHAMBER ELEVATIONS

DESCRIPTION	ELEVATION (FEET)
BOTTOM OF CHAMBER	0.00
PUMP OFF	1.08
PUMP ON	2.83
ALARM	3.17
LAG PUMP ON	3.50

NOTE:

24" DIAMETER POLY RISERS & LIDS OR CUSTOM RECTANGULAR RISERS WITH ALUMINUM HATCHES ARE AVAILABLE AS SUBSTITUTES TO CONCRETE GRADE RINGS AS SHOWN HEREON.

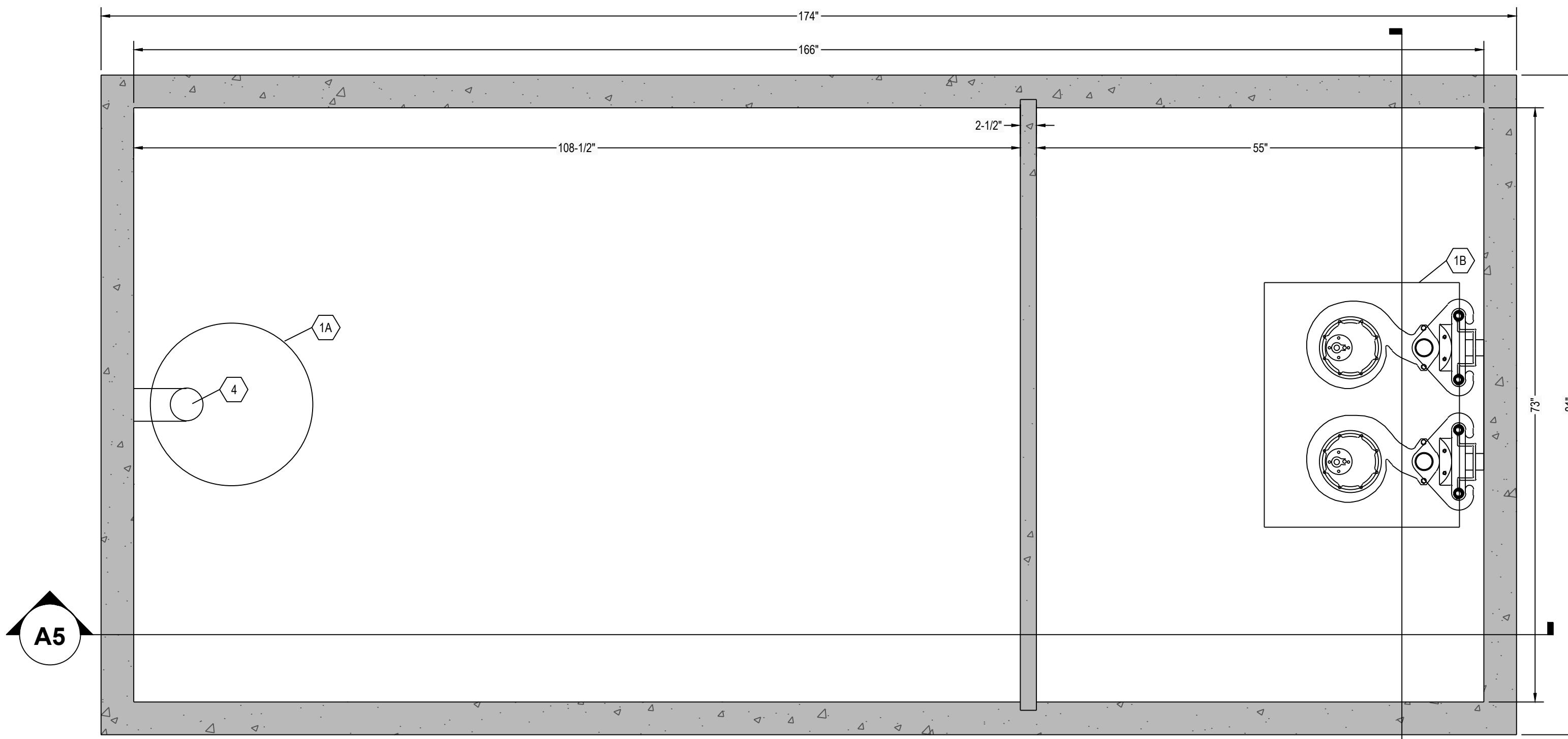

A5

C3

C5 SEPTIC TANK TOP VIEW

1" = 1"

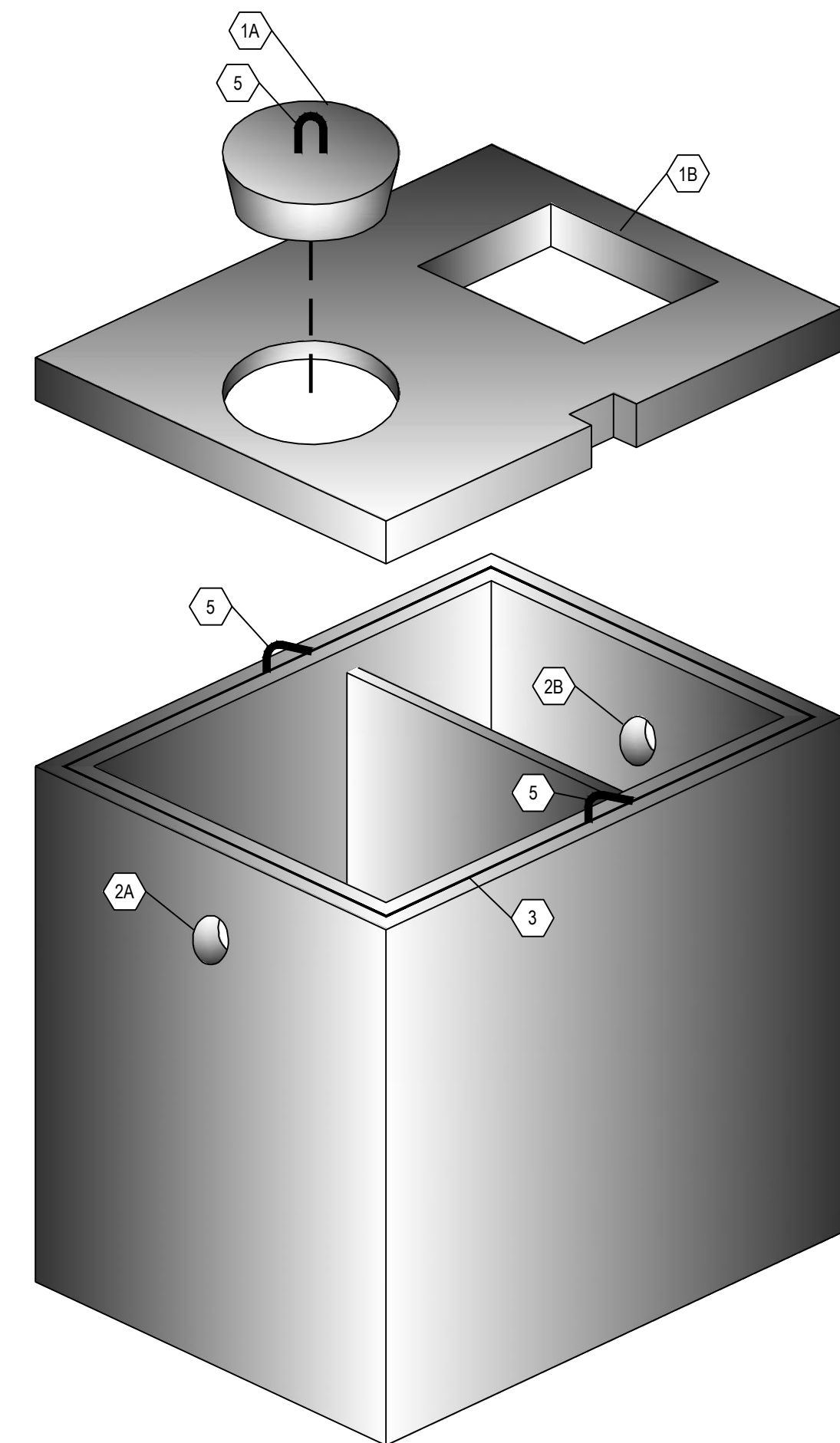

A6 THREE DIMENSIONAL ISOMETRIC VIEW

NTS

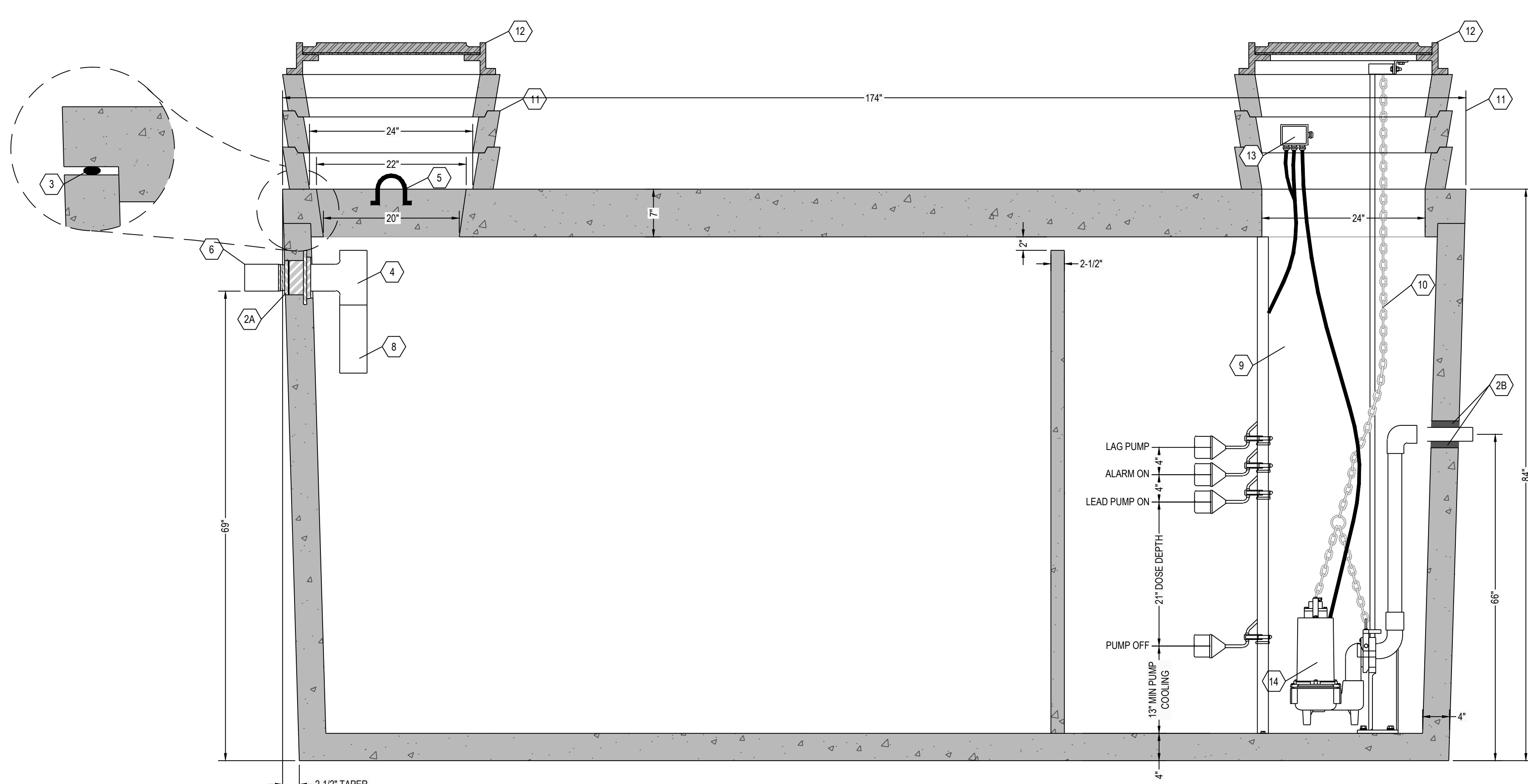

A5 SEPTIC TANK SECTION VIEW

1" = 1"

C3 SEPTIC TANK SECTION VIEW

1" = 1"

KEYNOTE INDEX

1A	24" DIAMETER MANWAY
1B	24" X 30" MANHOLE OPENING
2A	HIGH PRESSURE CLOSED END BOOT SEAL
2B	TS-4PRO RUBBER GASKET SEAL BY TUF-TITE
3	MASTIC ROPE
4	SANITARY TEE AT INLET
5	1" DIAMETER LIFTING HOOKS
6	6" DIAMETER INLET
7	12" DIAMETER OUTLET
8	12" EXTENSION AT INLET
9	FLOAT POLE ASSEMBLY WITH STAINLESS STEEL HARDWARE
10	RAIL SYSTEM WITH STAINLESS STEEL RAILS & HARDWARE
11	CONCRETE GRADE RING (AS NECESSARY)
12	CAST FRAME & COVER (NOT INCLUDED)
13	WATERTIGHT ELECTRICAL JUNCTION BOX
14	DOSING PUMP
15	THREE (3) 6" DIAMETER HOLES THROUGH INTERIOR WALL

RENSELAER SEPTIC TANKS

1211 NORTH WESTON STREET
 P.O. BOX 70
 RENSSELAER, INDIANA 47978
 phone: (219) 866-5063
 (800) 240-5123
 fax: (219) 866-3894

PROJECT NAME
 CLIENT NAME
 ADDRESS

PROJECT NO:
 FILE: 3000 GAL-DUAL-TR-DUPLEX.DWG
 DRAWN BY: ASJM
 CHECKED BY: PEW

TITLE:
**MANUFACTURER'S
 DETAIL DRAWING**
 3000 GALLON (2) COMPARTMENT
 DUPLEX DOSING
 TRAFFIC RATED

R-000

* ALL RENSSELAER SEPTIC TANKS ARE MONOLITHICALLY Poured *

This drawing is the property of Rensselaer Septic Tanks. It is submitted for reference purposes only. © 2008 Rensselaer Septic Tanks