

6

5

4

3

2

1

E

D

C

B

A



C5 SEPTIC TANK TOP VIEW
1" = 1"

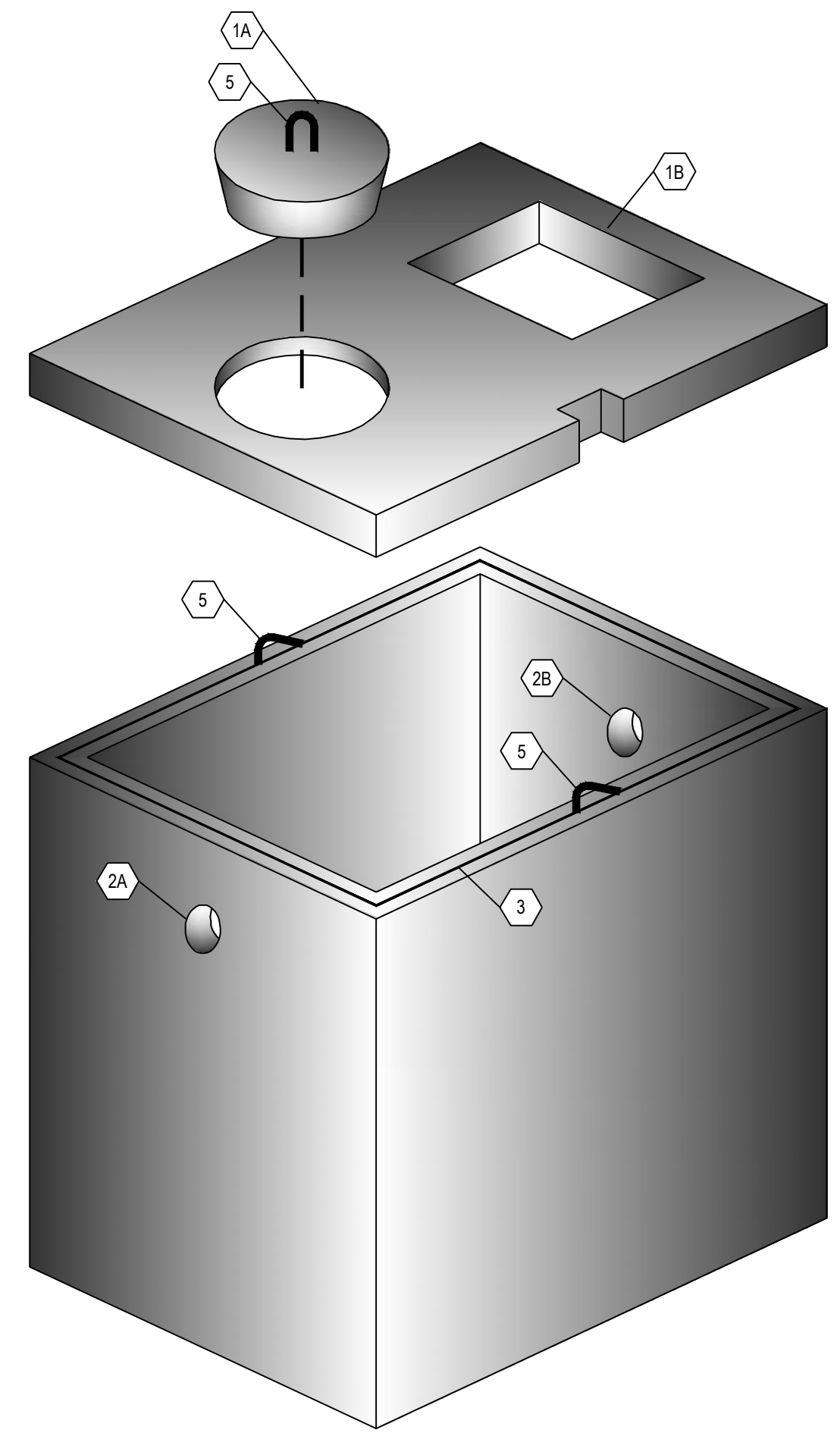

A6 THREE DIMENSIONAL ISOMETRIC VIEW
NTS

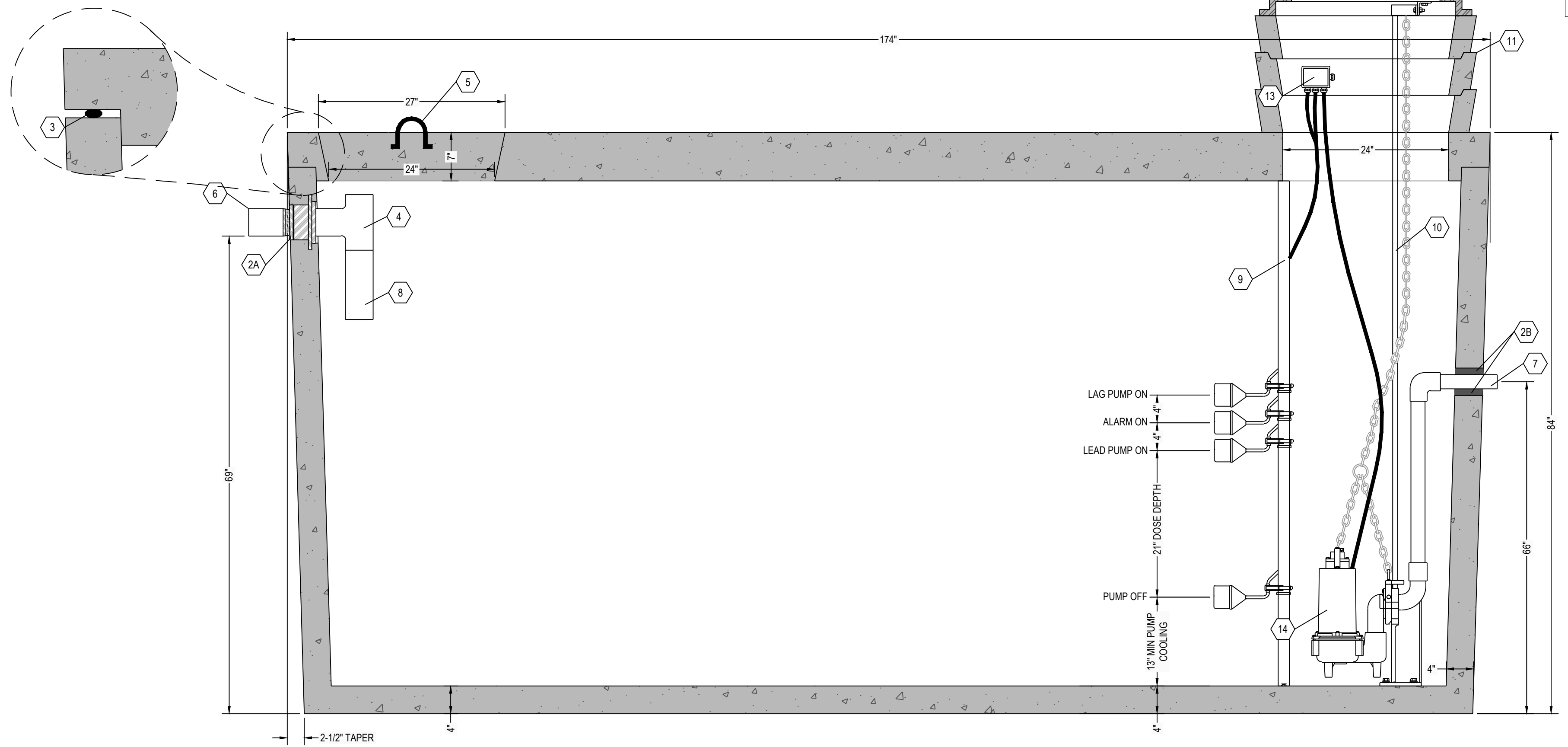

A5 SEPTIC TANK SECTION VIEW
1" = 1"

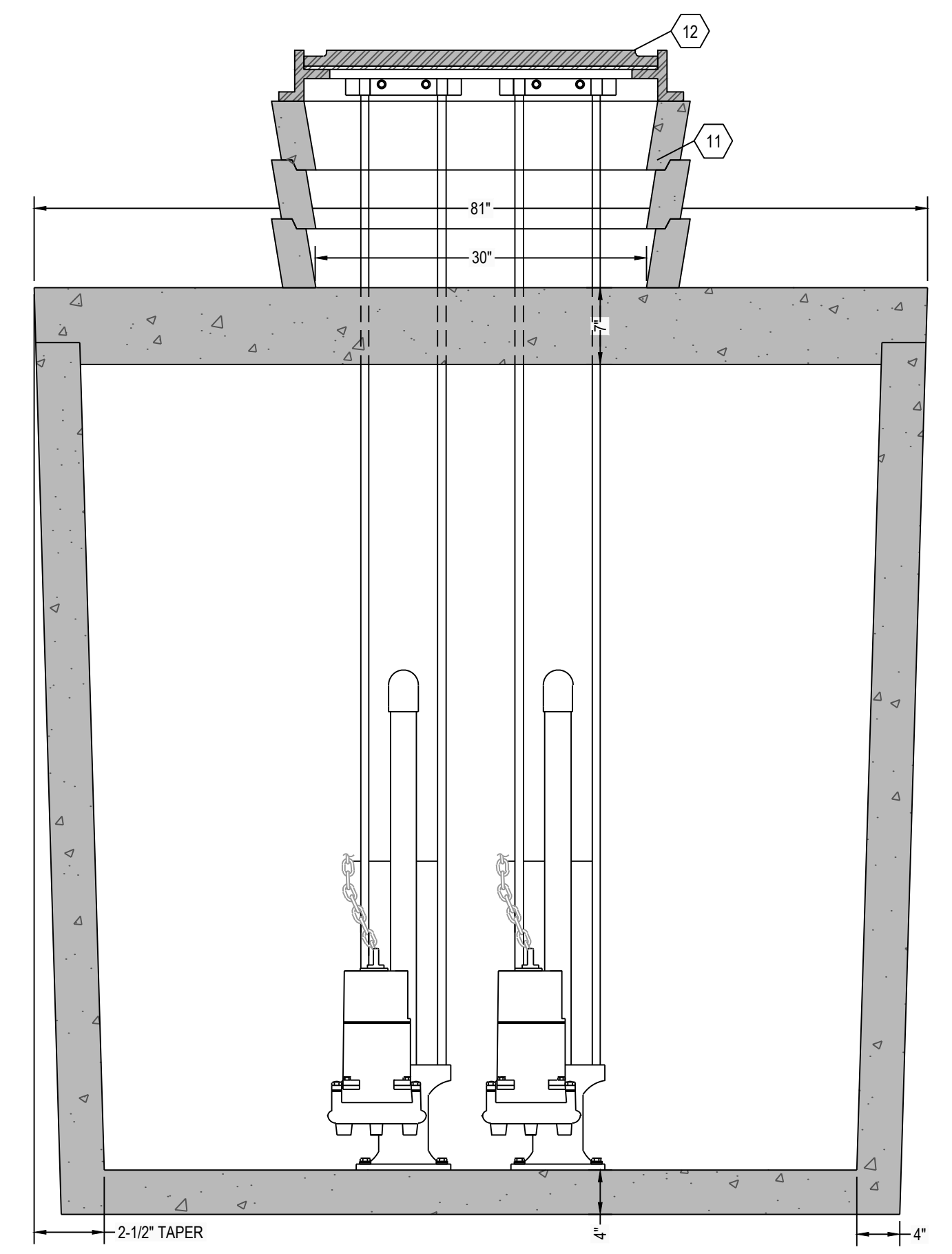

C3 SEPTIC TANK SECTION VIEW
1" = 1"

CASTING WEIGHTS
WEIGHT OF LID: 8,497.6 LBS
WEIGHT OF TANK: 17,222.8 LBS
TOTAL CASTING WEIGHT: 25,720.4 LBS

DOSING TANK CAPACITY:
LIQUID STORAGE = 3112 GALLONS
TOTAL VOLUME = 3695 GALLONS

50.2 GALLONS PER INCH
MAXIMUM DOSE = XXX GALLONS (XX)
PUMP COOLING = 653 GALLONS (13")
UNUSED (LAG AND ALARM) = 402 GALLONS (8")
TOTAL = XXX GALLONS (XX)

- NOTES:**
1. SET PUMP ON FLOAT SWITCH ELEVATION ACCORDING TO ELEVATION TABLE (BELOW), WHICH YIELDS THE REQUIRED DOSE VOLUME OF XXX GALLONS.
 2. CONTRACTOR SHALL INSTALL CONTROL PANEL ACCORDING TO PUMP MANUFACTURER'S RECOMMENDATION.
 3. COORDINATE POWER & ALARM SERVICE PRIOR TO CONSTRUCTION ACTIVITIES.
 4. ONLY NON-CORROSIVE MATERIALS SHALL BE UTILIZED WITHIN THE DOSING TANK AND FOR THE RISER AND LID (NO GALVANIZED, PAINTED, OR EXPOSED STEEL).
 5. AUDIO VISUAL ALARM CIRCUIT MUST LOCK ON WITH ANY PUMP FAILURE WITH MANUAL RESET.

DOSING CHAMBER ELEVATIONS

DESCRIPTION	ELEVATION (FEET)
BOTTOM OF CHAMBER	0.00
PUMP OFF	1.08
PUMP ON	2.83
ALARM	3.17
LAG PUMP	3.50

NOTE:
24" DIAMETER POLY RISERS & LIDS OR CUSTOM RECTANGULAR RISERS WITH ALUMINUM HATCHES ARE AVAILABLE AS SUBSTITUTES TO CONCRETE GRADE RINGS AS SHOWN HEREON.

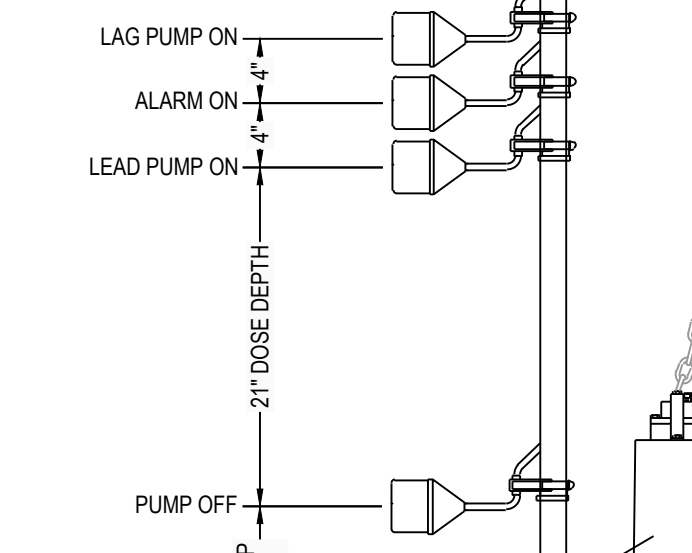

*** ALL RENSSELAER SEPTIC TANKS ARE MONOLITHICALLY POURED ***

RENSSELAER SEPTIC TANKS

1211 NORTH WESTON STREET
P.O. BOX 70
RENSSELAER, INDIANA 47978
phone: (219) 866-5063
(800) 240-5123
fax: (219) 866-3894

PROJECT NAME
CLIENT NAME
ADDRESS

PROJECT NO: _____
FILE: 3000 GAL- SINGLE TR- DUPLEX.DWG
DRAWN BY: ASJM
CHECKED BY: PEW
TITLE:
**MANUFACTURER'S
DETAIL DRAWING**
3000 GALLON DUPLEX CHAMBER
TRAFFIC RATED

R-000

This drawing is the property of Rensselaer Septic Tanks. It is submitted for reference purposes only. © 2008 Rensselaer Septic Tanks