

**DESIGN DATA:**

1. EARTH COVER = 3 FEET MAX
2. ALLOWABLE WHEEL LOAD = 2500 LB MAX
3. CONCRETE MINIMUM COMPRESSIVE STRENGTH = 5,000 PSI @ 28 DAYS
4. VAULT LID IS REINFORCED WITH 6 X 6 W8.0 X W8.0 WELDED WIRE FABRIC.
5. VAULT BOTTOM AND SIDES ARE REINFORCED WITH 6 X 6 W10.0 X W10.0 WELDED WIRE FABRIC.

**CASTING WEIGHTS**

WEIGHT OF LID: 8,497.6 LBS  
 WEIGHT OF TANK: 17,222.8 LBS  
 TOTAL CASTING WEIGHT: 25,720.4 LBS

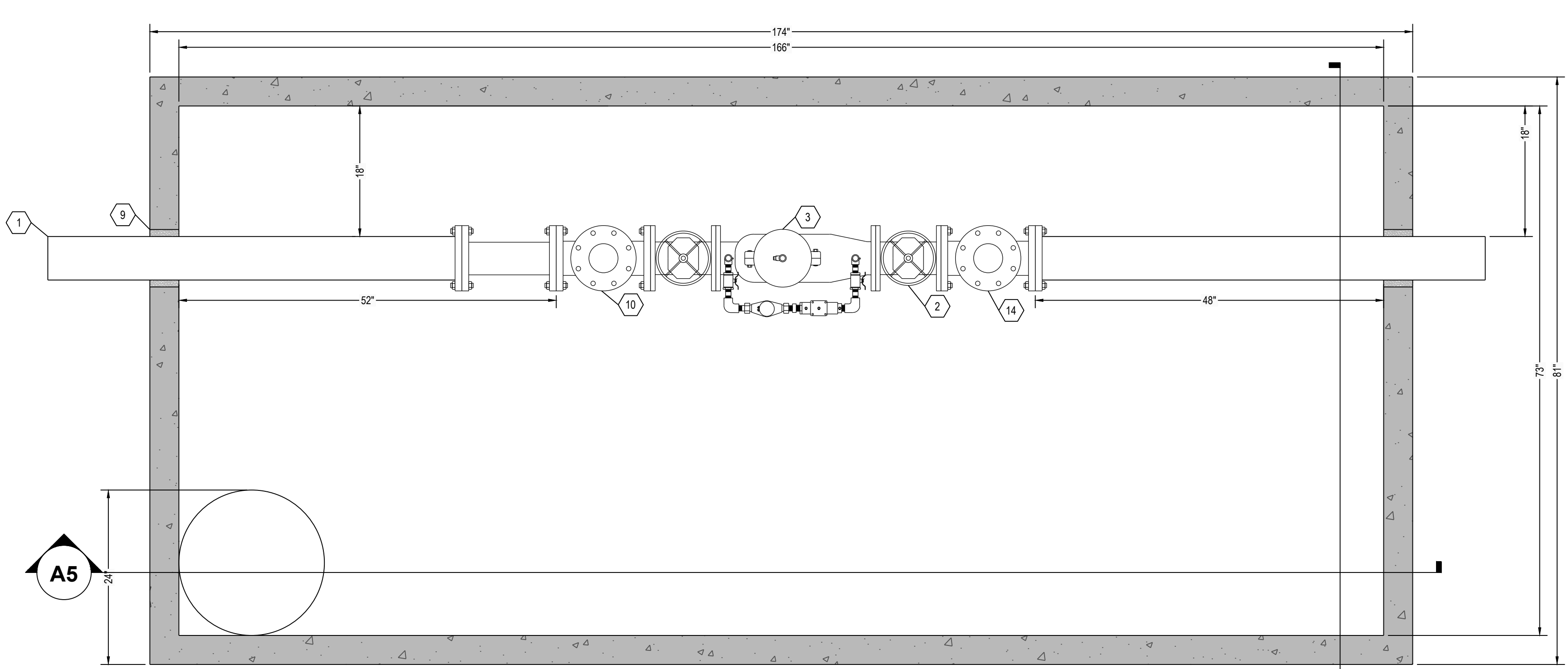

**C6 WATER METER VAULT TOP VIEW**  
1" = 1"

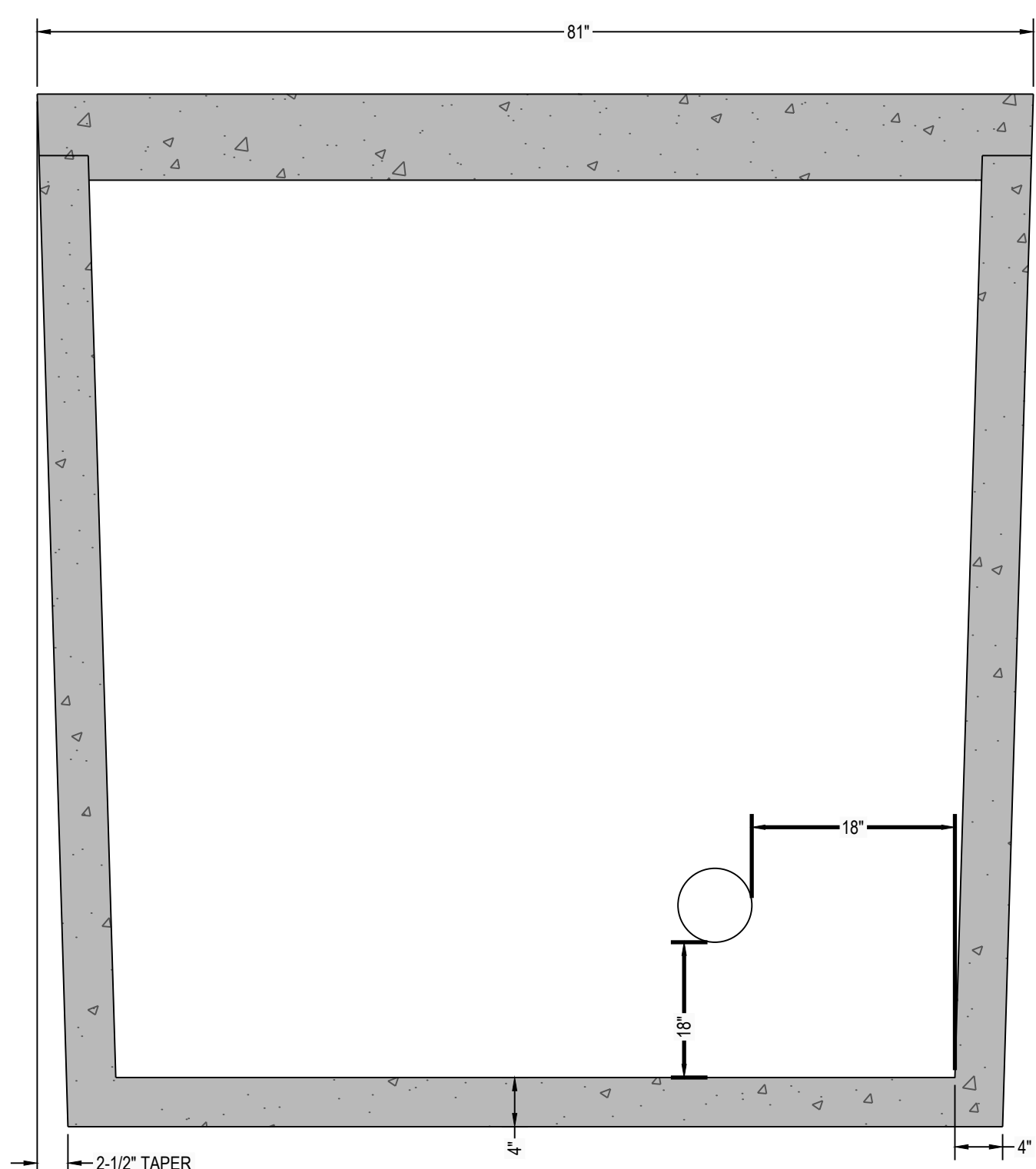

**C4 WATER METER VAULT SECTION VIEW**  
1" = 1"

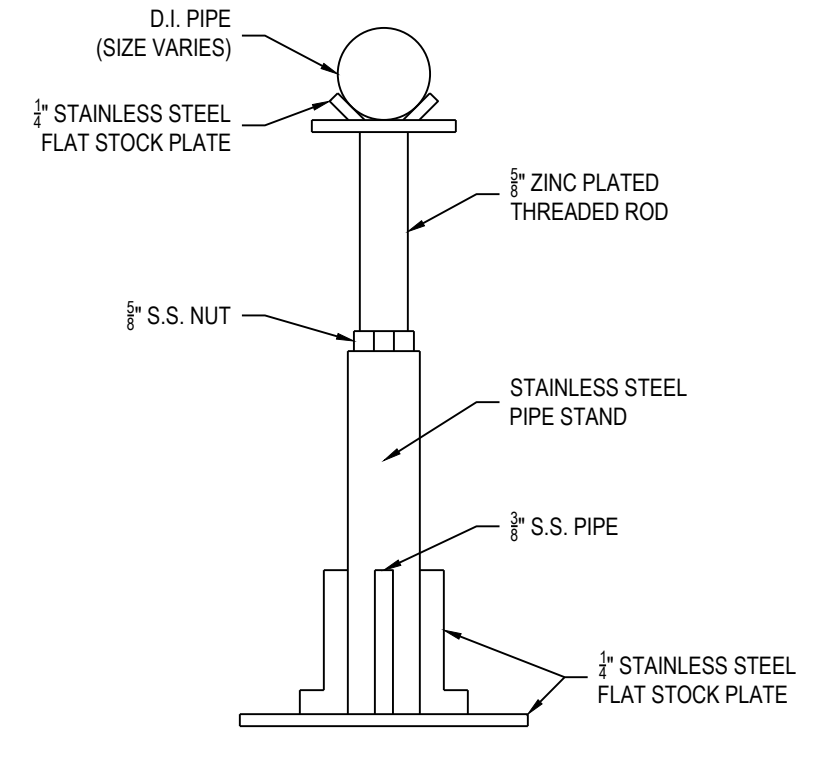

**D1 PIPE SUPPORT DETAIL**  
NTS

**H2O LOAD BEARING VAULTS ARE ALSO AVAILABLE INCLUDING LARGER HATCHES, GRADE RINGS, AND OTHER CUSTOM MODIFICATIONS THAT CAN BE MADE TO MEET JOB REQUIREMENTS, FOR ADDITIONAL CHARGES.**

**VAULTS CAN BE ORDERED: ASSEMBLED, UNASSEMBLED, OR WITH NO CONTENTS.**

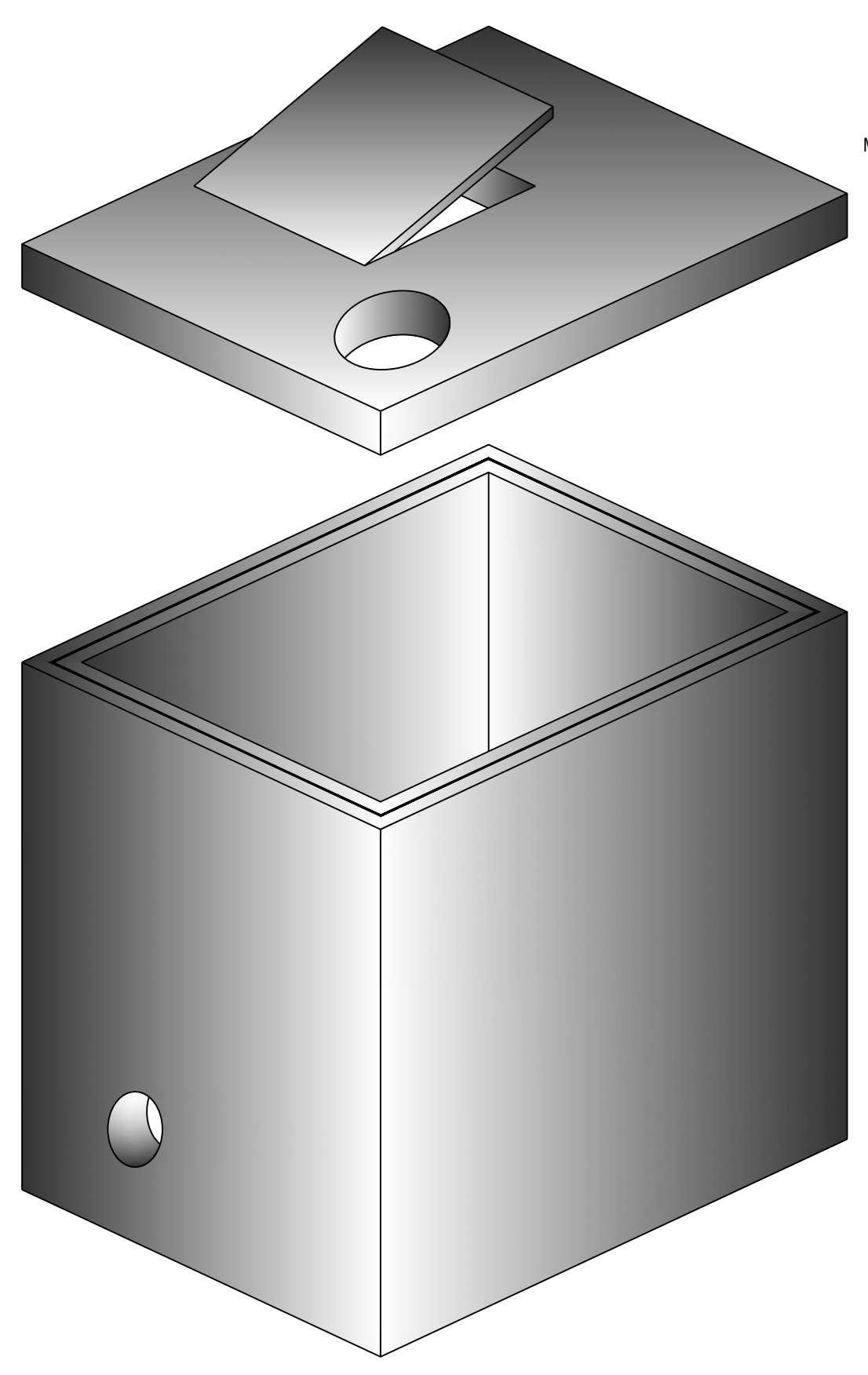

**A6 THREE DIMENSIONAL ISOMETRIC VIEW**  
NTS

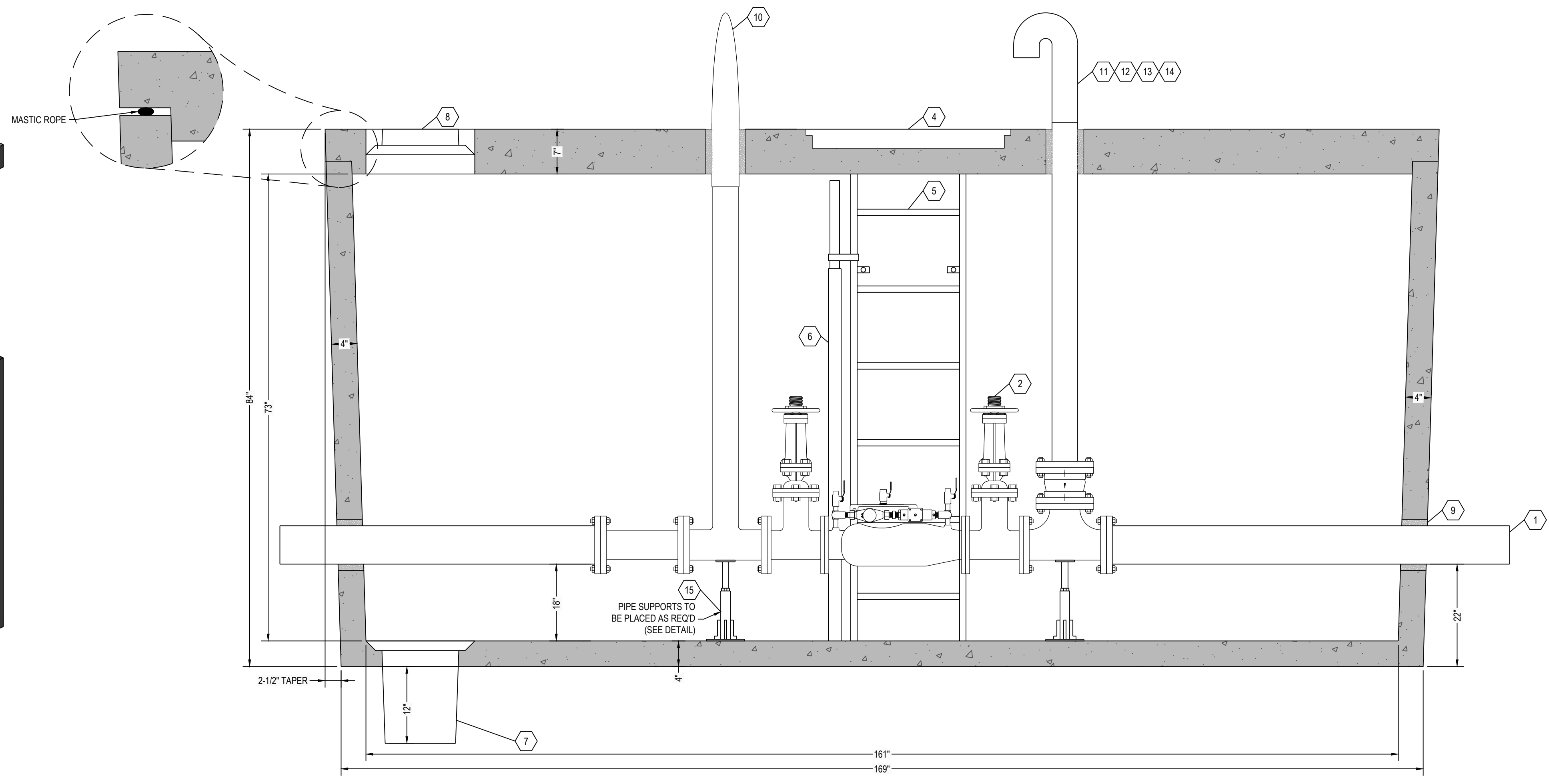

**A5 WATER METER VAULT SECTION VIEW**  
1" = 1"

ITEM	QTY	ITEM DESCRIPTION
1	2	6" X VARIES D.I. PIPE
2	2	6" DIA. OS&Y VALVE
3	1	6" DOUBLE CHK. ASSEMBLY, DETECTOR-AMES 3000SS
4	1	30" SQUARE ALUMINUM HATCH- SEE NOTES
5	1	6'-1" ALUMINUM LADDER- SEE NOTES
6	1	ALUMINUM USF TYPE LADDERUP SAFETY DEVICE
7	1	SUMP PIT (20" DIAMETER) WITH GRATE
8	1	SUMP PUMP LID, SEE NOTE BELOW
9	4	HIGH PRESSURE OPEN END BOOT SEAL (TYP)
10	1	PIV - PIT TYPE POST INDICATOR VALVE
11	1	4" GALV STREET 90
12	1	5" X 4" STORZ CONNECTION WITH CAP
13	1	4" WAFER CHECK VALVE
14	1	FDC - FIRE DEPARTMENT CONNECTION
15	2	STAINLESS STEEL PIPE SUPPORT

**NOTES**  
 HATCH TO BE 30" X 30" ALUMINUM HATCH, 300 PSF, SINGLE DOOR, INCLUDING ANGLE FRAME, STAINLESS STEEL NUTS & BOLTS, STAINLESS STEEL HINGES, STAINLESS STEEL AUTOMATIC HOLD-OPEN ARM WITH RED VINYL GRIP, FLUSH LIFT HANDLE, TAMPER PROOF FASTENERS, AND EXPOSED PADLOCK STAPLE.  
 LADDER TO BE O.S.H.A. COMPLIANT ALUMINUM FLOOR/WALL MOUNT LADDER FABRICATED FROM 3/8" X 2 1/2" FLAT BARS AND 1 1/2" SQUARE EXTRUDED RUNGS, WITH SLIP RESISTANT RUNGS 12" ON CENTER, 18" WIDE WITH STANDARD MINIMUM 7" OFFSET MOUNTED WITH STAINLESS STEEL ANCHORS AND BOLTS.  
 SUMP PUMP LIDS SHALL BE FORD A53-TT OR A53-T. THE A53-TT WILL BE USED FOR ALL VAULTS WITH THE DOMESTIC WATER INSIDE. THE A53-T WILL BE USED FOR ALL VAULTS WITH THE DCCDA ONLY LOCATED INSIDE THE VAULT.

# RENSELAER SEPTIC TANKS

1211 NORTH WESTON STREET  
 P.O. BOX 70  
 RENSELAER, INDIANA 47978  
 phone: (219) 866-5063  
 (800) 240-5123  
 fax: (219) 866-3894

**PROJECT NAME**  
**CLIENT NAME**  
**ADDRESS**

PROJECT NO: **08012**  
 FILE: IAW 3000 GAL VAULT TR.DWG  
 DRAWN BY: TVL  
 CHECKED BY: PEW  
 TITLE: **MANUFACTURER'S DETAIL DRAWING**  
 3000 GALLON WATER METER VAULT  
 TRAFFIC RATED

**R-000**

**\* ALL RENSELAER SEPTIC TANKS ARE MONOLITHICALLY POURED \***