

6 5 4 3 2 1

- DESIGN DATA:**
- EARTH COVER = 3 FEET MAX
 - ALLOWABLE WHEEL LOAD = 2500 LB MAX
 - CONCRETE MINIMUM COMPRESSIVE STRENGTH = 5,000 PSI @ 28 DAYS
 - VAULT LID IS REINFORCED WITH 6 X 6 W8.0 X W8.0 WELDED WIRE FABRIC.
 - VAULT BOTTOM AND SIDES ARE REINFORCED WITH 6 X 6 W10.0 X W10.0 WELDED WIRE FABRIC.

CASTING WEIGHTS

WEIGHT OF LID: 8,497.6 LBS
 WEIGHT OF TANK: 17,222.8 LBS
 TOTAL CASTING WEIGHT: 25,720.4 LBS

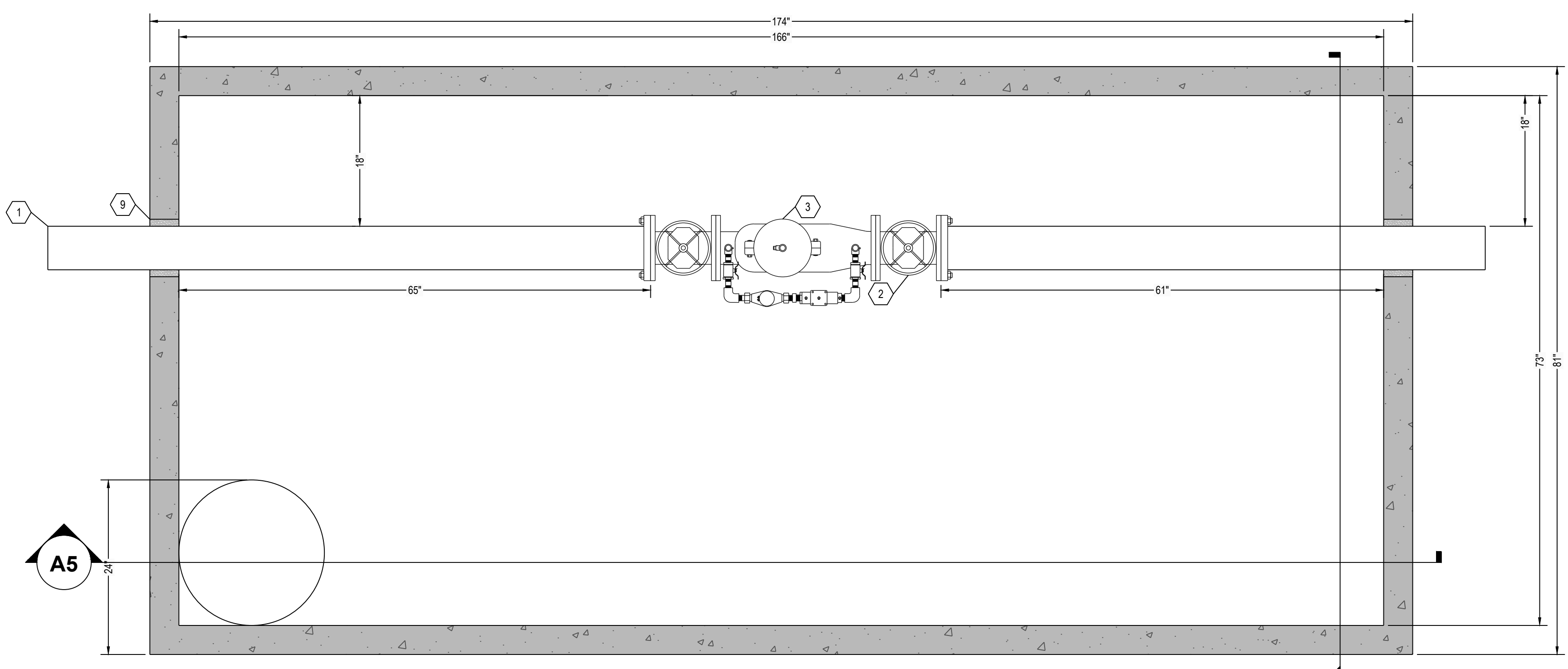

C6 WATER METER VAULT TOP VIEW
1" = 1"

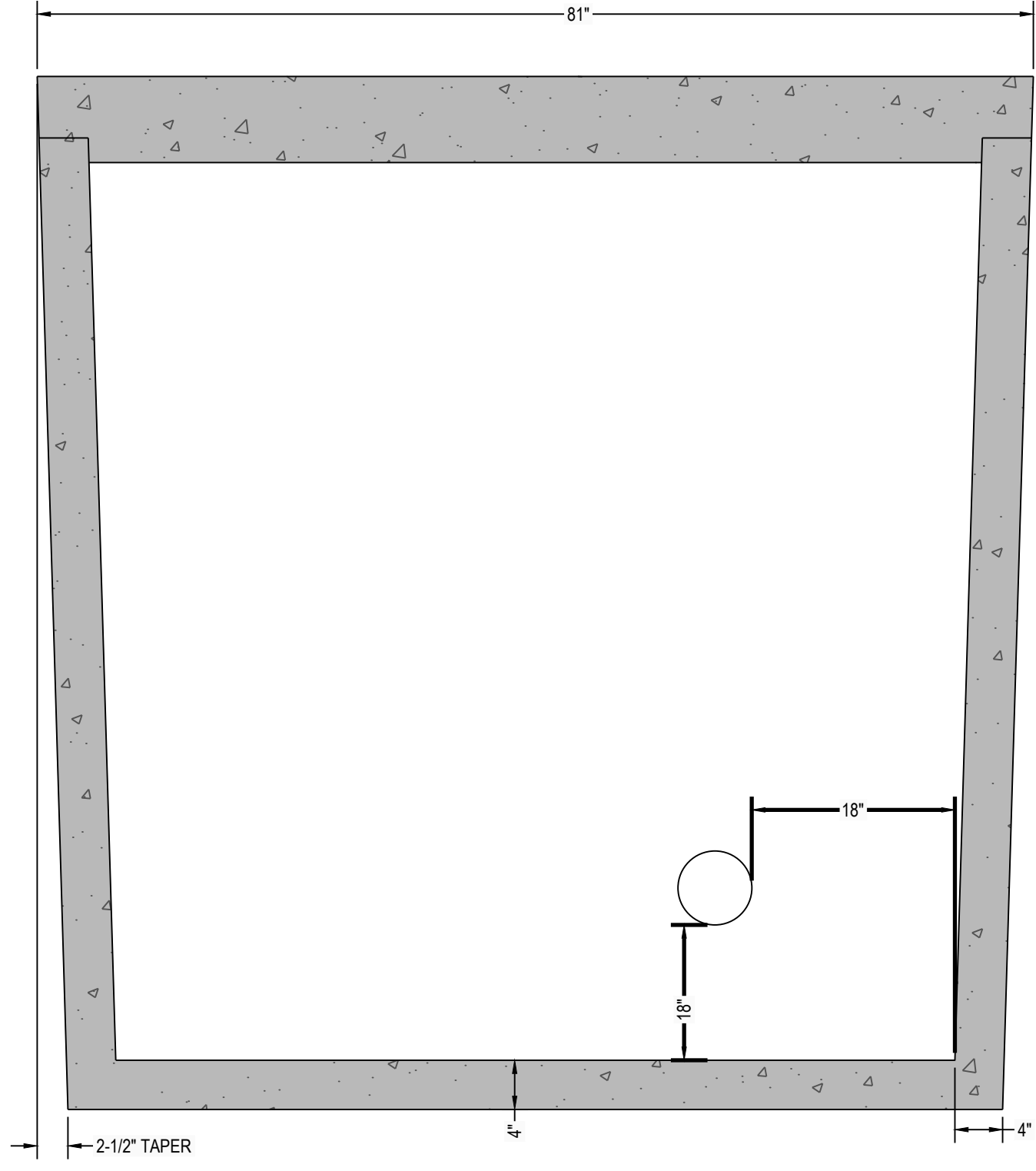

C4 WATER METER VAULT SECTION VIEW
1" = 1"

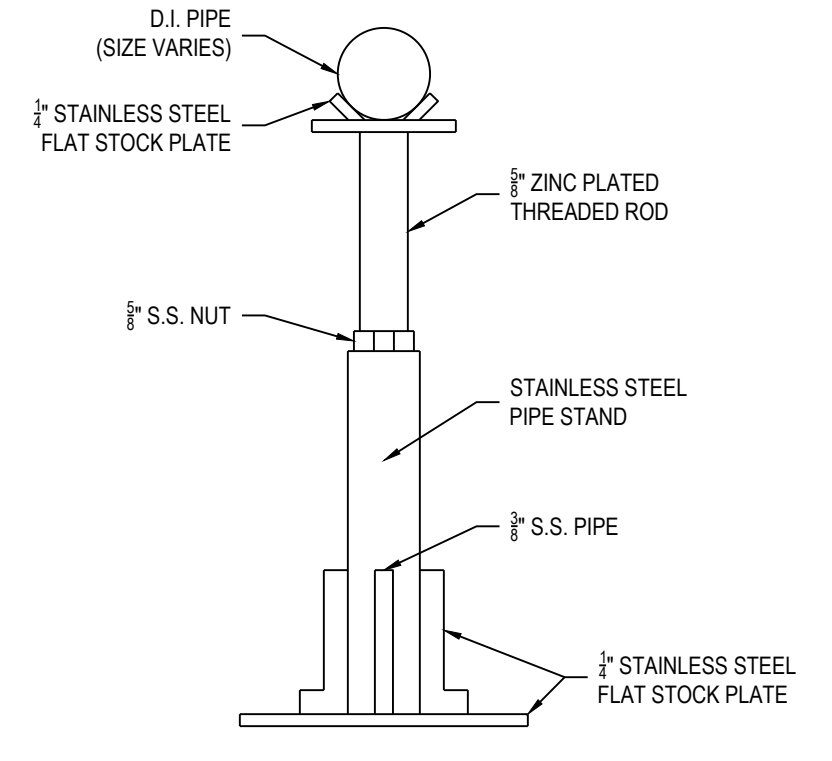

D1 PIPE SUPPORT DETAIL
NTS

H2O LOAD BEARING VAULTS ARE ALSO AVAILABLE INCLUDING LARGER HATCHES, GRADE RINGS, AND OTHER CUSTOM MODIFICATIONS THAT CAN BE MADE TO MEET JOB REQUIREMENTS, FOR ADDITIONAL CHARGES.

VAULTS CAN BE ORDERED: ASSEMBLED, UNASSEMBLED, OR WITH NO CONTENTS.

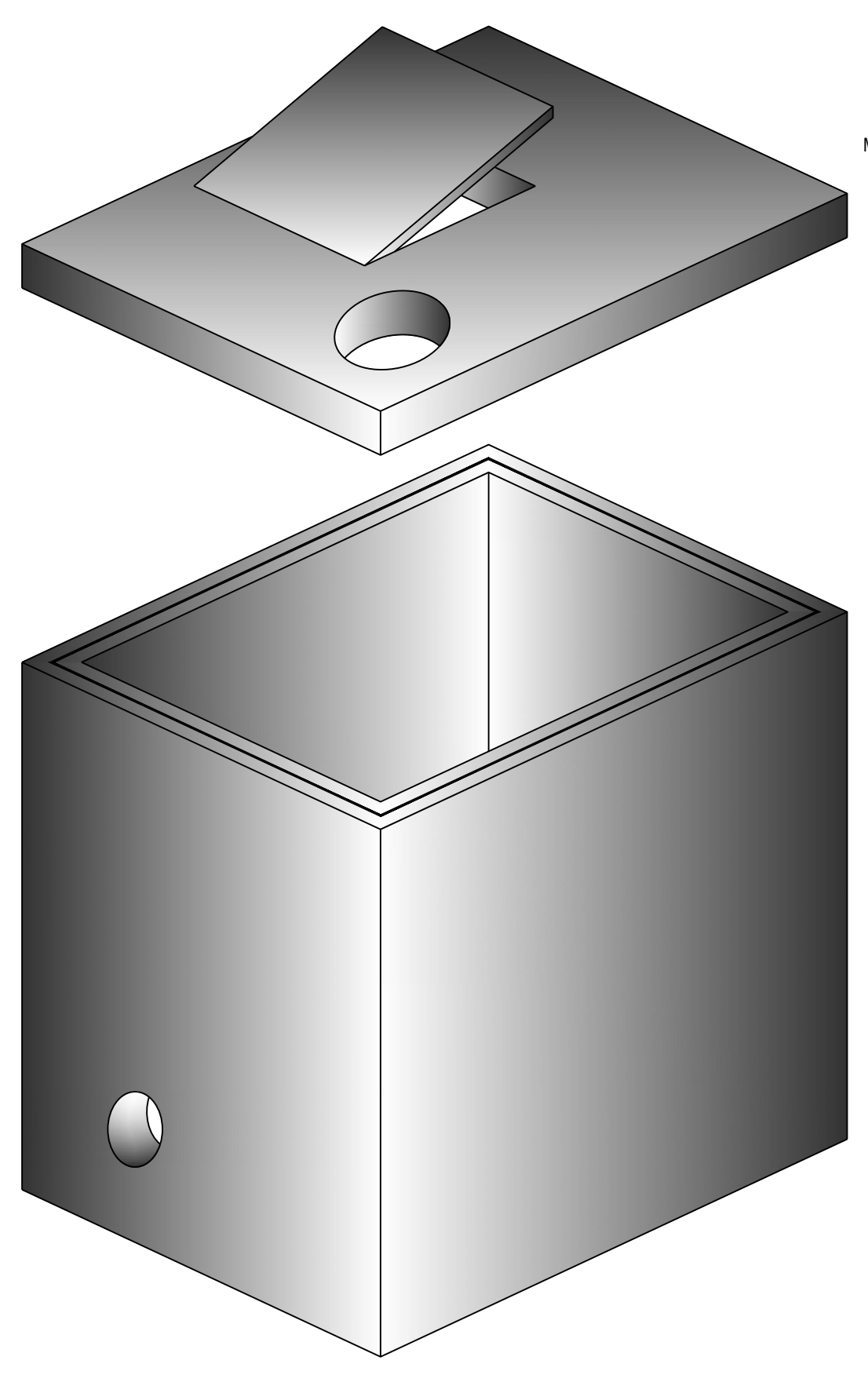

A6 THREE DIMENSIONAL ISOMETRIC VIEW
NTS

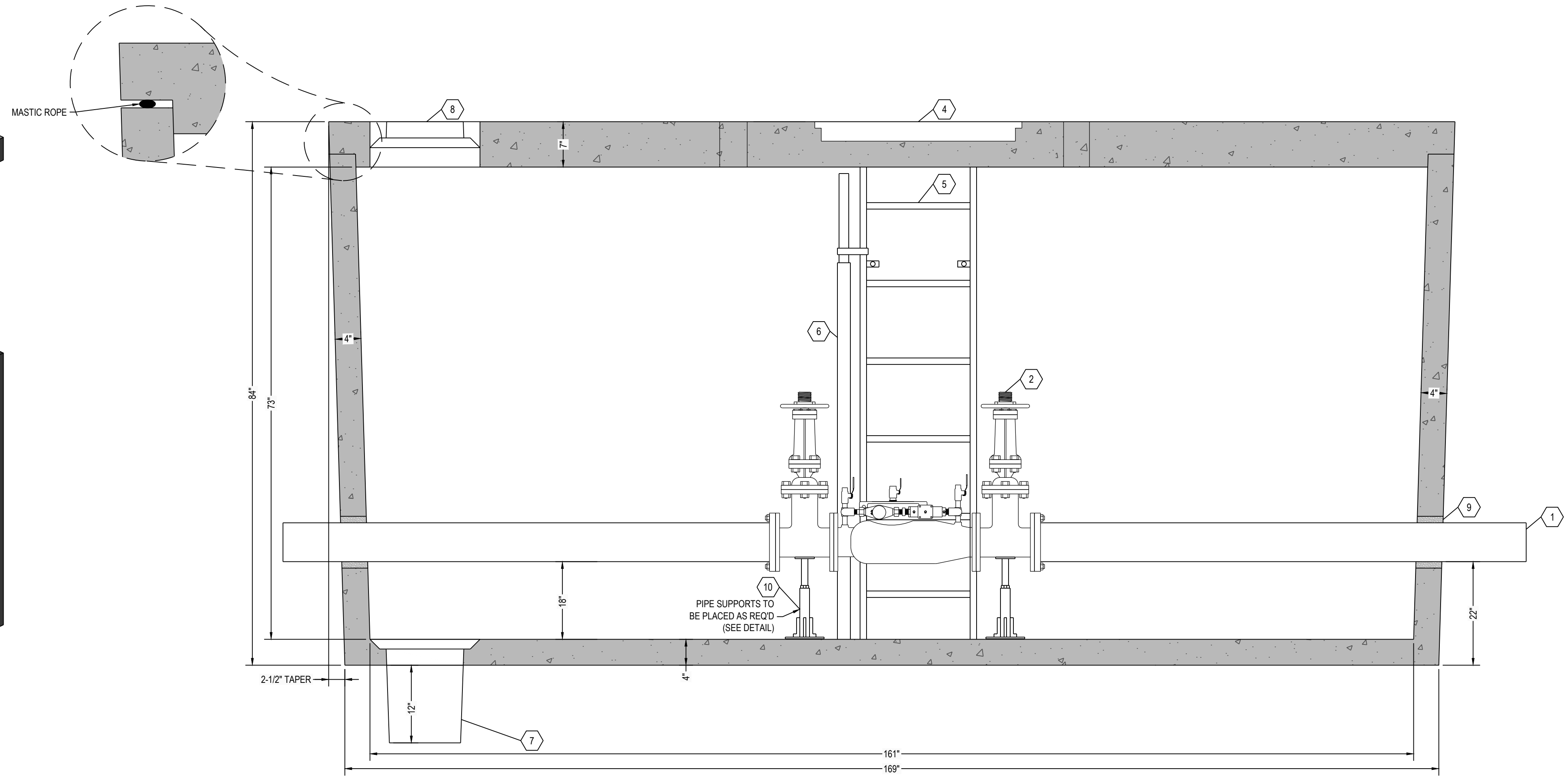

A5 WATER METER VAULT SECTION VIEW
1" = 1"

ITEM	QTY	ITEM DESCRIPTION
1	2	6" X VARIES D.I. PIPE
2	2	6" DIA. OS&Y VALVE
3	1	6" DOUBLE CHK. ASSEMBLY, DETECTOR-AMES 3000SS
4	1	30" SQUARE ALUMINUM HATCH- SEE NOTES
5	1	6'-1" ALUMINUM LADDER- SEE NOTES
6	1	ALUMINUM USE TYPE LADDERUP SAFETY DEVICE
7	1	SUMP PIT (20" DIAMETER) WITH GRATE
8	1	SUMP PUMP LID. SEE NOTE BELOW
9	4	HIGH PRESSURE OPEN END BOOT SEAL (TYP)
10	2	STAINLESS STEEL PIPE SUPPORT

NOTES

HATCH TO BE 30" X 30" ALUMINUM HATCH, 300 PSF, SINGLE DOOR, INCLUDING ANGLE FRAME, STAINLESS STEEL NUTS & BOLTS, STAINLESS STEEL HINGES, STAINLESS STEEL AUTOMATIC HOLD-OPEN ARM WITH RED VINYL GRIP, FLUSH LIFT HANDLE, TAMPER PROOF FASTENERS, AND EXPOSED PADLOCK STAPLE.

LADDER TO BE O.S.H.A. COMPLIANT ALUMINUM FLOOR/WALL MOUNT LADDER FABRICATED FROM 3/8" X 2 1/2" FLAT BARS AND 1 1/2" SQUARE EXTRUDED RUNGS, WITH SLIP RESISTANT RUNGS 12" ON CENTER, 18" WIDE WITH STANDARD MINIMUM 7" OFFSET MOUNTED WITH STAINLESS STEEL ANCHORS AND BOLTS.

SUMP PUMP LIDS SHALL BE FORD A53-TT OR A53-T. THE A53-TT WILL BE USED FOR ALL VAULTS WITH THE DOMESTIC WATER INSIDE. THE A53-T WILL BE USED FOR ALL VAULTS WITH THE DCOA ONLY LOCATED INSIDE THE VAULT.

RENSELAER SEPTIC TANKS

1211 NORTH WESTON STREET
 P.O. BOX 70
 RENSELAER, INDIANA 47978
 phone: (219) 866-5063
 (800) 240-5123
 fax: (219) 866-3894

PROJECT NAME
 CLIENT NAME
 ADDRESS

PROJECT NO: **08012**
 FILE: IAW 3000 GAL VAULT TR-NO PIV.DWG
 DRAWN BY: TVL
 CHECKED BY: PEW

TITLE:
MANUFACTURER'S DETAIL DRAWING
 3000 GALLON WATER METER VAULT
 TRAFFIC RATED

R-000

*** ALL RENSELAER SEPTIC TANKS ARE MONOLITHICALLY POURED ***

6 5 4 3 2 1

This drawing is the property of Rensselaer Septic Tanks. It is submitted for reference purposes only. © 2008 Rensselaer Septic Tanks